

Manual HMB Units

EN

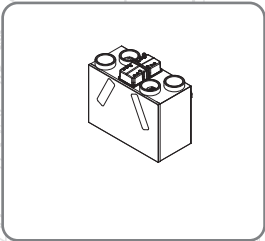

HRV 1.35 *Q Plus*

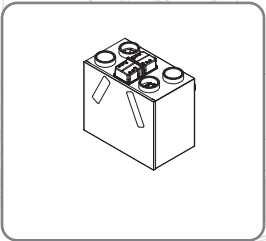

HRV 1.6 *Q Plus*

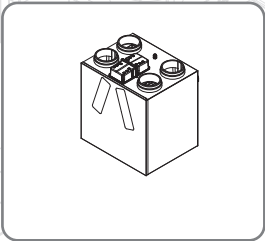

HRV4 *Q Plus*
HRV4.25 *Q Plus*



Warnings, Safety Information and Guidance





Important Information

Important: read these instructions fully before the installation of this appliance

1. Installation of the appliance and accessories must be carried out by a qualified and suitable competent person and be carried out in clean, dry conditions where dust and humidity are at minimal levels.
2. This manual covers the installation of the Heat Recovery Ventilation (HRV) unit
3. All wiring must conform to current I.E.E. Wiring Regulations and all applicable standards and Building Regulations.
4. Inspect the appliance and electrical supply cord. If the supply cord is damaged, it must be replaced by the manufacturer, their service agent or similarly qualified persons in order to avoid a hazard.
5. The unit is supplied with a mains rated 3 core flexible cord (PVC sheathed, brown, blue and green/yellow 0.75mm²).
6. The appliance must be connected to a local double pole isolation switch with a contact separation of at least 3mm.
7. The appliance must be earthed.
8. HRV1.35, HRV1.6 & HRV4 *Q Plus* units suitable for 230V ~ 50/60Hz single phase with a fuse rating of 3A.
9. HRV4.25 *Q Plus* suitable for 230V ~ 50/60Hz single phase with a fuse rating of 5A.
10. Switch and Boost cable access is achieved by knockouts in the terminal box and fitting a cable gland suitable for Ø3-6mm cable.
11. Switch and Boost cables – Unshielded 2 core minimum 18-24AWG Stranded, Tinned Copper.
12. All Control, Boost & Communication cables should not be placed within 50mm or on the same metal cable tray as any 230V~ lighting or power cables.
13. Ensure all cable glands are fully tightened.
14. The unit must be stored in a clean and dry environment.
15. Do not install the appliance in areas where the following may be present or occur;

-
- Excessive oil or a grease laden atmosphere,
 - Corrosive or flammable gases, liquids or vapours.
 - Ambient temperatures above 40°C or below -5°C.
 - Humidity levels above 90% or is a wet environment.
16. The appliance is not suitable for installation to the exterior of the dwelling.
 17. This appliance can be used by children aged from 8 years and above and persons with reduced physical, sensory or mental capabilities or lack of experience and knowledge if they have been given supervision or instruction concerning use of the appliance in a safe way and understand the hazards involved. Children should be supervised to ensure that they do not play with the appliance. Cleaning and user maintenance shall not be made by children without supervision.
 18. Ensure that external grilles are located away from any flue outlet, in accordance with relevant Building Regulations.
 19. The unit must not be connected to a tumble dryer or a cooker hood.
 20. Heat recovery systems and extract fans can create negative pressures within rooms. Ensure precautions are taken to avoid negative pressure creating a back-flow of gases into the room from an open flue.
 21. Ensure all ducting, condensate drain and associated pipe work is free from debris and blockages before switching on the unit.

Explanation of symbols on the appliance

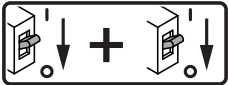
Symbol	Definition
	Read instruction Manual.
	Risk of Electric Shock.
	General hazard safety alert.
	Wait until all machine components have completely stopped before touching them.
	Disconnect the mains supply before removing this cover.
	Disconnect the mains supply before removing this cover. Before obtaining access to terminals or removing this cover, all supply circuits must be disconnected.



This symbol on this unit or the package, indicates that disposal of this unit after its life-cycle could harm the environment.

Do not dispose the unit as unsorted municipal waste; it should be disposed by a specialized company for recycling. This unit should be returned to your distributor or to a local recycling service. Respect the local environmental rules.

Manufacture Recommend:

- Any flexible ducting should only be used for final terminations only and must be a maximum of 300m long and be pulled taut, and straight.
- A minimum distance of 200mm between the MVHR unit and any sharp bends in duct work.
- Ducting should be insulated where it passes through unheated areas and voids with the equivalent of at least 25mm of a material having a thermal conductivity of ≤ 0.04 W/(m.K) to reduce the possibility of condensation forming. Where a duct extends externally above roof level the section above the roof should be insulated or a condensate trap should be fitted just below roof level.
- Ducts within the building heated envelope between the external terminals and the unit's From Atmosphere and To Atmosphere ports should be insulated and wrapped additionally with a vapour barrier outside the insulation.
- Where duct pass through any fire barriers or walls, they must comply with the requirements of local Building Regulations.
- A ducting condensate drain must be fitted to vertical To Atmosphere duct work.
- Ducting must be installed in such a way that resistance to airflow is minimised.
- Ducting connected to the From Atmosphere & To Atmosphere ports, must be to/from the external air outside the building envelope.
- Duct joints to the unit's duct ports must be fixed using a method that ensures a long term seal is achieved. If using a short piece of flexible ducting secure using a hose clamp, do not over tighten hose clamp; as overtightening may distort and reduce the unit's port.
- A minimum distance of 2m exists between the external supply and exhaust terminals.

Contents

Warnings, Safety Information and Guidance		Installation	
Important Information	2	Unit Mounting	13
Explanation of symbols on the appliance	4	Safety Bracket	13
Manufacture Recommend:	5	Left Hand Units	
Units		Blanking Plug	14
List of Products	7	Condensate Drain	
Product Information		The Condensate Drain:	15
Packaging Contents	8	Right Hand Units	
Units' Weights	8	Handing Change	16
Units' Dimensions		Handing Switch	16
HRV1.35 <i>Q Plus</i>	9	Blanking Plug	17
HRV1.6 <i>Q Plus</i>	9	Ducting Connections	
HRV4 & 4.25 <i>Q Plus</i>	9	Port Designations	18
Product Features		Wiring	
Speed Control	10	Wiring Access	19
Setback Speed	10	Supply	19
Continuous Speed	10	Switching & Controls	20
Boost Speed with Overrun Timer	10	Commissioning	
Boost Alert	10	Commission with built in Controls	23
auralite	10	Control Parameters	23
Summer Bypass	11	Continuous Supply & Extract Speeds:	23
SUMMERboost®	11	Boost Supply & Extract Speeds:	24
Automatic Frost Protection	11	Boost Overrun	24
Integrated Humidity Sensor	11	Humidity Sensor	24
Filter Change	11	Controller Reset	24
Axillary Connection Socket compatibility	11	Hardware Reset	24
		Maintenance	
		Routine Maintenance	25
		Cleaning Exterior	25
		Cleaning Interior	25
		HRV1.35, 1.6, 4 & 4.25	25
		Front Cover Removal	25
		Condensate Tray	25
		Filter Replacement	26
		HRV1.35, 1.6, 4 & 4.25	26



When this document is viewed as a PDF the headings & sub headings on this page are hyper links to the content. Additionally the page numbers in this document are hyper links back to this contents page.

List of Products

This Manual is for the following Products

TP408HMB	HRV1.35
TP408HMB_LT	HRV1.35 with aura-lite
TP409HMB	HRV1.6
TP409HMB_LT	HRV1.6 with aura-lite
TP421HMB	HRV4
TP421HMB_LT	HRV4 with aura-lite
TP423HMB	HRV4.25
TP423HMB_LT	HRV4.25 with aura-lite

Product Information

The Titan HRVs are Mechanical Ventilation with Heat Recovery (MVHR) units. They are designed for the energy efficient ventilation of dwellings. The units are designed for continuous ventilation, exhausting stale moist air from bathrooms, toilets, kitchen and utility rooms.

As the stale air is extracted, the unit's heat exchanger transfers heat, which would have been wasted, to the fresh air being supplied to the bedrooms and living rooms.

Packaging Contents

Inspect the unit when taking delivery. Each unit is supplied with various accessories. Check the unit for damage and that all unit specific accessories have been supplied.

Unit	Accessory	Mounting Bracket	Safety Bracket(s) Kit	Condensate Drain Olive & Nut	M6x10 Pan HD screw	M6 washer	Transport Bungs	Product Manual	EuP Documentation
HRV1.35									
HRV1.6		2	1	1	4	4	4	1	Yes
HRV4 & 4.25									

Units' Weights

Unit	Compatible Ducting (mm)	Weight (kg)
HRV1.35	Ø125	16
HRV1.6	Ø125	22
HRV4 & 4.25	Ø150 & Ø160	28.5

Units' Dimensions

The following diagrams detail the overall size of the units, the duct port positions & the additional space required around the units (Service Void - - -) to allow for commissioning and future service and maintenance.

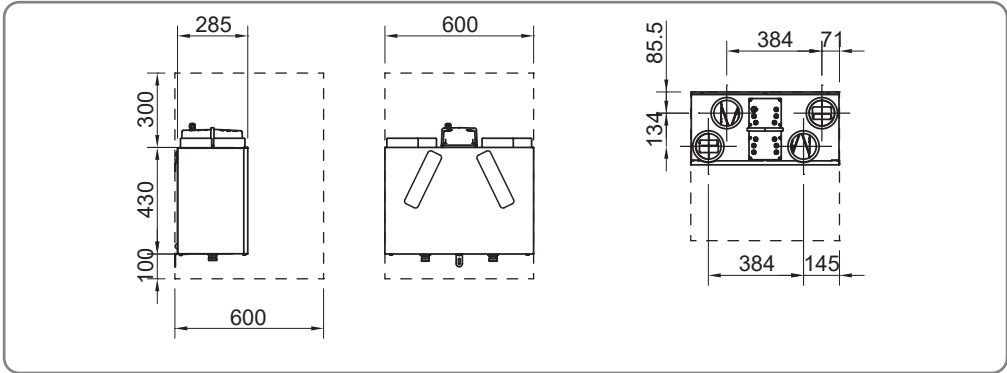

HRV1.35 Q Plus

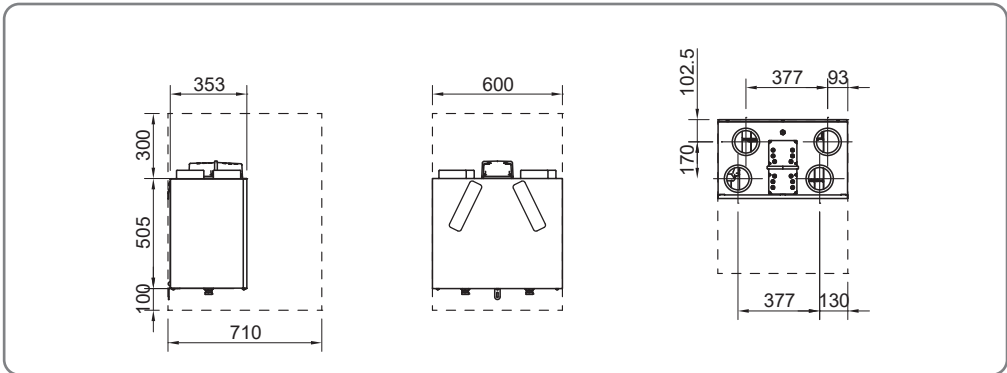

HRV1.6 Q Plus

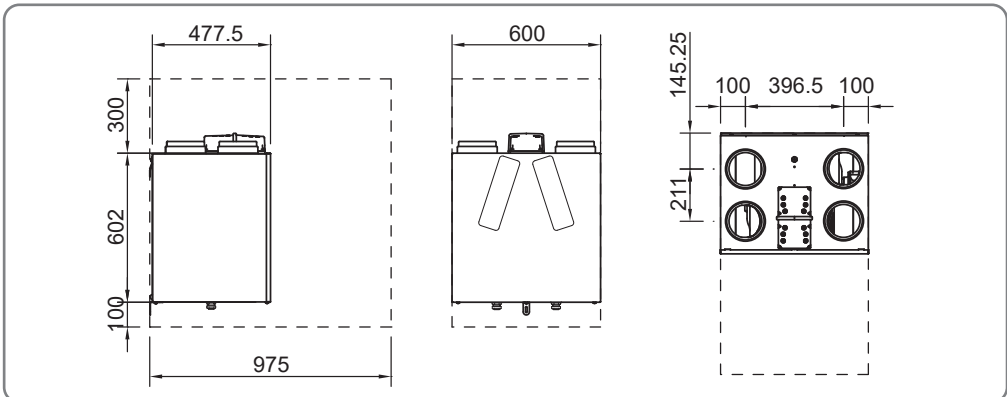

HRV4 & 4.25 Q Plus

Product Features

The MVHRs come in two standard versions: one with a factory-installed auralite status indicator, and one without. See Axillary Connection Socket compatibility.

auralite

The auralite status indicator has six LEDs which display:

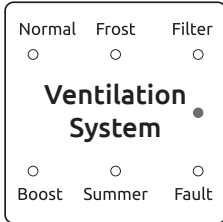

- **Normal** Solid - Unit is running at Continuous Speed.
Flashing - Unit is running at Setback Speed.
 - **Frost** Unit is in Automatic Frost Protection mode.
 - **Filter** Filters require change.
 - **Boost** Solid - Unit is running at Boost Speed.
Flashing - Boost Alert is active.
 - **Summer** Unit is in Summer bypass.
 - **Fault** Unit has a fault - Contact the installer.
- When the top and bottom rows of LEDs are flashing alternately, this indicates that the on-board auralite's operation is paused because an auxiliary controller is connected.

The following describes the HRVs features and how they are controlled

Speed Control

- The units have four speeds. Speed 2 and Speed 3 are user adjustable via the controllers' rotary controls.
- Speed 1 - Setback - Reduced ventilation.
- Speed 2 - Continuous - Normal ventilation.
- Speed 3 - Boost - Increased ventilation.
- Speed 4 - SUMMERboost®.

Setback Speed

Setback Speed is used to reduce ventilation rates. Setback Speed is automatically set at the mid point between the minimum possible Continuous Speed and the selected Continuous Speed. The Setback Speed is used by connecting a volt free one-way switch, or combined with the Boost Speed with the 3 position switch TP 508; and will be triggered when the switch is closed.

Continuous Speed

Continuous Speed is the normal continuous extract and supply air flow running speed of the units.

Boost Speed with Overrun Timer

Boost Speed increases the extract and supply air flow. Boost Speed is configured with Step-less rotary controls and includes an Overrun Timer variable between 0 and 60 minutes. The Boost Speed can be triggered by any device which provides a volt free one-way switch, such as a PIR, thermostat, humidistat or a standard one-way switch.

Boost Alert

Boost Alert is a timer designed to prevent the HRV being inadvertently left in Boost for long periods of time. When the HRV is placed in Boost the timer is started and after 2 hours Boost Alert will be activated and the Overrun Timer is disabled. The HRV will return to Continuous Speed as soon as the switch holding the unit in Boost is released.

If an auralite is connected this is indicated by the Boost LED on the auralite®.

Summer Bypass

Summer Bypass is designed to operate during hot periods where fresh air can be vented straight into the property without being preheated by the extracted stale air. Summer Bypass operation is automatically controlled. The Summer Bypass mechanism diverts the stale air being extracted from the dwelling around the heat cell so that its heat energy is not transferred to the fresh air being supplied to the property.

SUMMERboost®

An optional SUMMERboost® facility is available that allows both the supply and extract fans to run at full speed whenever the Summer Bypass is activated. By default SUMMERboost® is disabled by a Link Wire, see Wiring Diagrams.

Removal of the link wire will enable SUMMERboost®. When SUMMERboost® is triggered by Summer Bypass the increased fan speed can be prevented either Manually or Automatically.

Manual - This is by means of a latching volt-free switch wired directly into the controller PCB.

Automatic - This is by means of a dedicated wall mounted room thermostat. SUMMERboost® will only operate when the temperature has exceeded the thermostat setting. Should the room temperature fall below the thermostat setting, then SUMMERboost® will not operate.

Automatic Frost Protection

During very cold weather, Automatic Frost Protection will detect temperatures that could form ice inside the unit. It will reduce the supply ventilation rate to prevent ice build up within the heat cell. Automatic Frost Protection reduces the flow rate of cold air, thus allowing the warmer stale air to raise the temperature within the heat cell to such a level that prevents the formation of ice. As internal temperatures rise Automatic Frost Protection will increase the supply ventilation flow rate back to the commissioned settings.

Integrated Humidity Sensor

Units are fitted with an Integrated Humidity Sensor. This continuously monitors the relative humidity (RH) of the extracted air. The sensors set point is variable from 55%RH to 85%RH and is configured using rotary control.

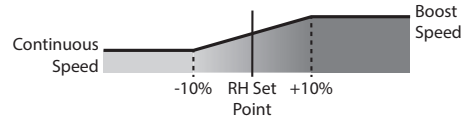

The fans' speed varies proportionally between Continuous Speed & Boost Speed depending on the measured %RH

Filter Change

Units are supplied with a 12 month timestrip. To indicate when the next filter change is due this should be fixed to the unit and activated. Additionally units with an auralite this will indicate a filter change is due every 6 months. The time period can be change with the service tool.

Axillary Connection Socket compatibility

All units are supplied with the connection socket. This socket enables the connection of axillary indicators, controllers and the service tool.

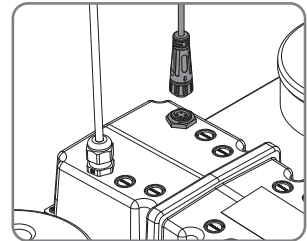

The socket is located on top of the electrical box, fitted with a protective cap.

MVHR	compatibility		
on-board auralite	external auralite	external aura-t	Service Tool
N	Y	Y	Y
Y	N	Y	Y

IMPORTANT

All units are supplied as Left Handed Units and can be reconfigured on site to Right Hand Units

Before installation of Ducting, Condensate Drain & the HRV, the hand of the installation must be confirmed and communicated to ALL persons involved with the installation and commissioning of the HRV.

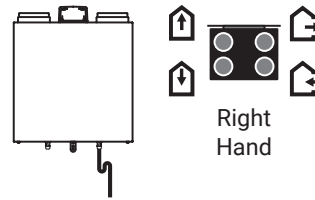
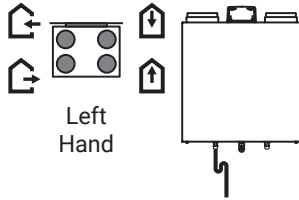

EXTRACT FROM DWELLING - This duct port is connected to the ducting that carries waste air from the 'Wet Rooms' to the HRV unit.



SUPPLY TO DWELLING - This duct port is connected to the ducting that carries the fresh warmed air to the habitable rooms from the HRV unit.



TO ATMOSPHERE - This duct port is connected to the ducting that carries the waste air to outdoors from the HRV unit.



FROM ATMOSPHERE - This duct port is connected to the ducting that carries fresh outdoor air to the HRV unit.

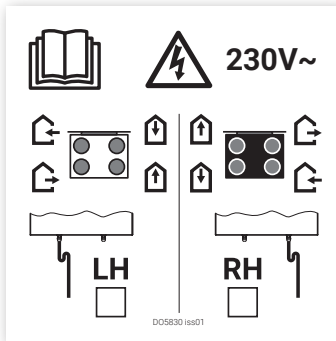

This label is affixed to the top of the unit it must be marked with a permanent marker to identify the handing of the unit.

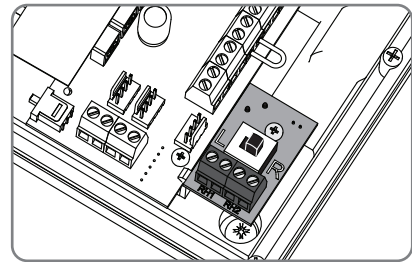

Handing of the unit is achieved by the physical connections to the unit; ducting & condensate drain and electronically via the Handing switch inside the electrical enclosure.

It is advised the handing switch position is checked and that it corresponds with the physical installation.

Unit Mounting

Read and observe the guidance & safety notices listed in Warnings, Safety Information and Guidance .

Do not remove the Port Covers, where fitted, until connecting ducting. Port Covers are fitted to prevent debris falling into the unit and causing blockages and damage:

- The mounting surface must be sufficiently strong to support the unit.
- Consider the positioning of electrical services and the Condensate Drain when siting the unit.
- Ensure there is sufficient access around the HRV Q Plus (Service Void - -) for future maintenance; see Units' Dimensions Section for details.
- Do not 'box-in' the unit making access to the unit difficult for maintenance and repair. (Duct Covers are available)

The Unit Must be mounted plumb and level front to back and side to side.

1. Mark a horizontal line on the wall using a spirit level. This line will be approximately 95mm below the location of the top face of the unit when fitted (excluding duct ports).
2. Use the Mounting Brackets as a template to mark the three fixing hole centres.
3. Drill holes for fixings, always use a fixing suited to the wall type.
4. Fix the Mounting Bracket to the wall ensuring the interlocking side is at the top; as shown. Mount the unit by locating the two mounting Brackets together.
5. Ensure a positive location is made between the two Mounting Brackets.

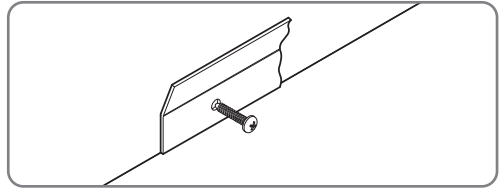

Safety Bracket

The Safety Bracket(s) MUST be used.

Fix the lower Safety Bracket as shown using the remaining M6 screw, washer and suitable wall fixing. Packing to be used as required behind the Safety Bracket to ensure unit is level

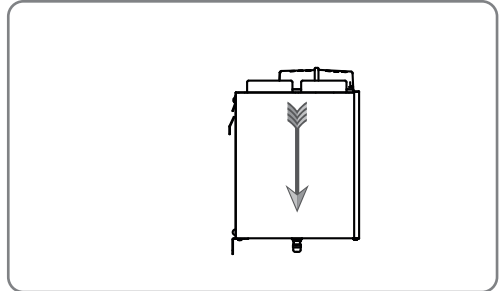

Hook Unit onto Wall Bracket

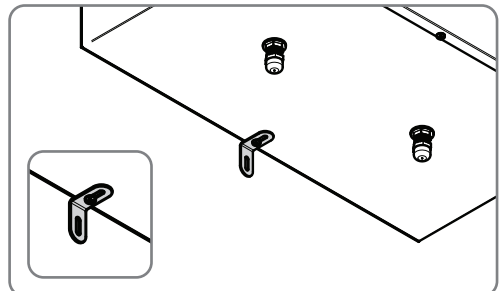

Left Hand Units

All units are supplied as Left Handed Units

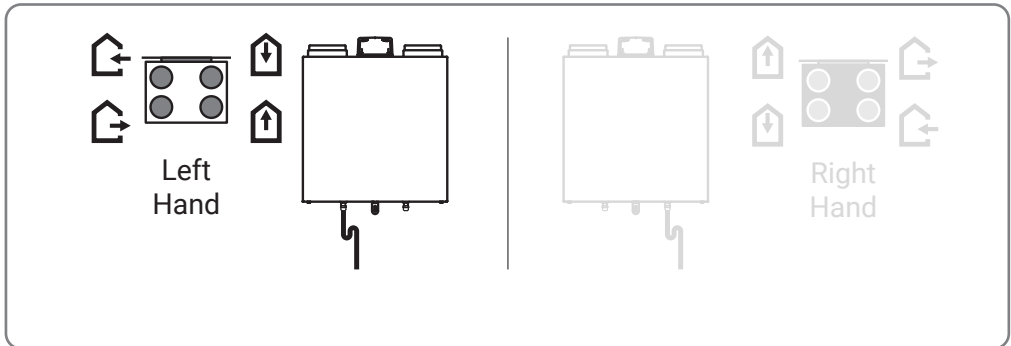

Left / Right Hand Drain Connection & corresponding Ducting Connections

1. Check the position of the Handing switch, inside the Terminal Box.
2. Connect the Condensate Drain pipe work to the Left Hand Condensate Outlet
3. Fit the Brass Blanking Plate to the Right Hand Condensates Outlet.
4. Use a permanent marker to identify the handing of the unit on the Port Identification and Handing Label affixed to the top of the unit.

Handing Switch

All units use the same Electronics Terminal Enclosure. The compartment has two removable lids. The front lid must always be removed before the rear lid; both lids are fixed by four screws.

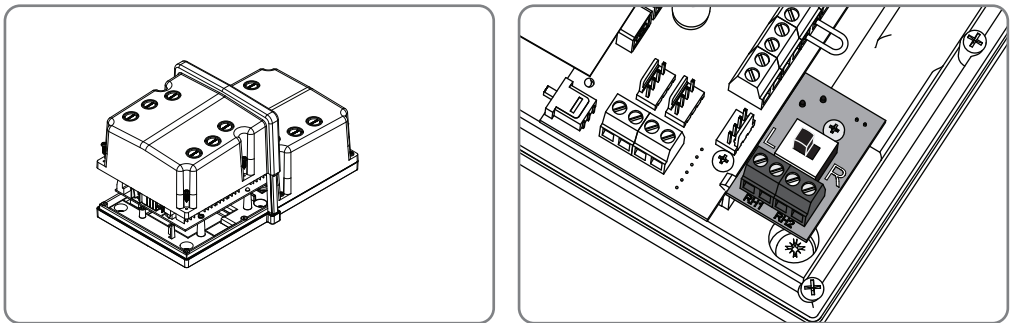

1. To access the handing switch remove the front wiring cover.
2. To change the MVHR handing move the switch to the desired position L Left Hand / R Right Hand.
3. Refit Cover and screws.

Left Hand Units

Blanking Plug

The Blanking plug must be fitted to the unused condensate outlet.



Condensate Outlet



Blanking Plate fitted to unused Outlet

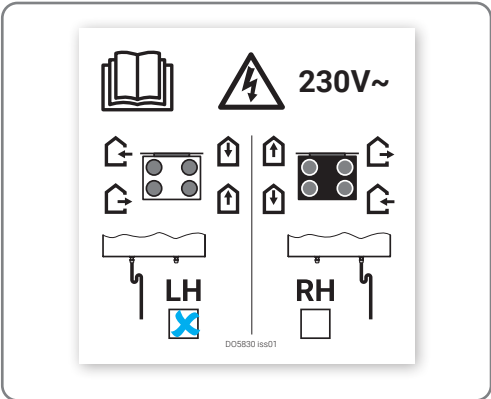

Port Identification & Handing Label

This label affixed to the top of the unit must be marked with permanent marker to identify the handing of the unit.



EXTRACT FROM DWELLING - This duct port is connected to the ducting that carries waste air from the 'Wet Rooms' to the HRV unit.



SUPPLY TO DWELLING - This duct port is connected to the ducting that carries the fresh warmed air to the habitable rooms from the HRV unit.



TO ATMOSPHERE - This duct port is connected to the ducting that carries the waste air to outdoors from the HRV unit.



FROM ATMOSPHERE - This duct port is connected to the ducting that carries fresh outdoor air to the HRV unit.

Right Hand Units

Handing Change

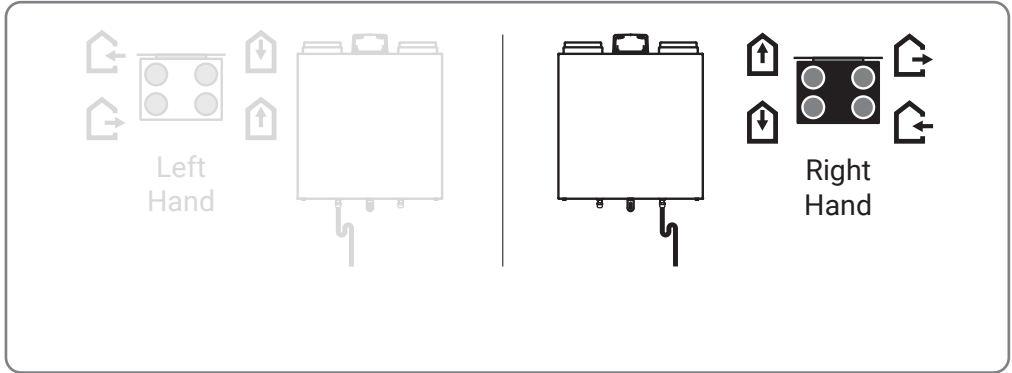

Left / Right Hand Drain Connection & corresponding Ducting Connections

1. Use the Handing switch, inside the Terminal Box.
2. Connect the Condensate Drain pipe work to the Right Hand Condensate Outlet
3. Fit the Brass Blanking Plate to the left-hand Condensates Outlet.
4. Use a permanent marker to identify the handing of the unit on the Port Identification and Handing Label affixed to the top of the unit.

Handing Switch

All units use the same Electronics Terminal Enclosure. The compartment has two removable lids. The front lid must always be removed before the rear lid; both lids are fixed by four screws.

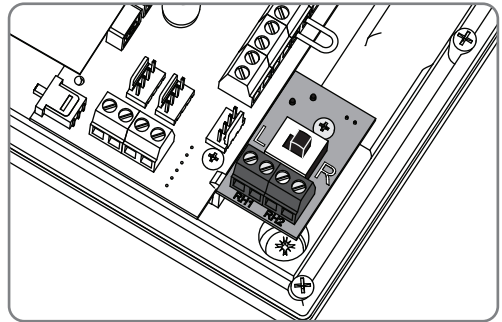
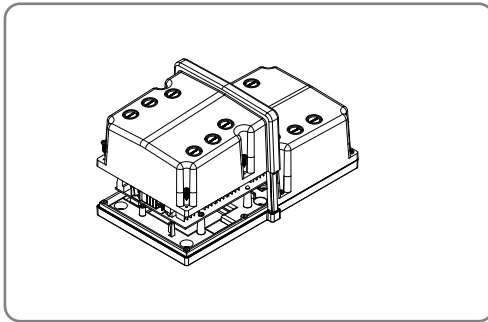

1. To access the handing switch remove the front wiring cover.
2. To change the MVHR handing move the switch to the desired position L Left Hand / R Right Hand.
3. Refit Cover and screws.

Blanking Plug

The Blanking plug must be fitted to the unused condensate outlet.

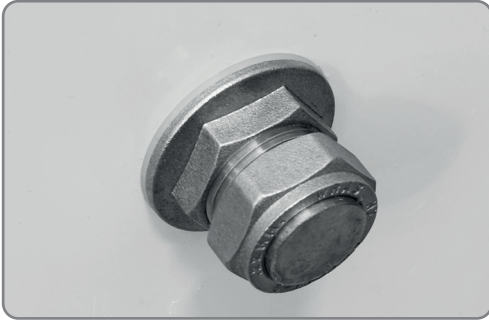

Blanking Plate fitted to Condensate Outlet



Condensate Outlet

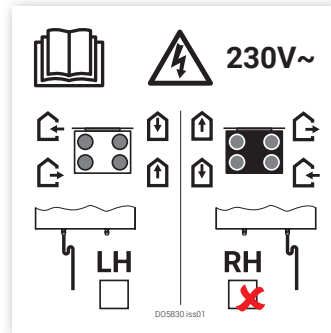

Port Identification and Handling Label

This label affixed to the top of the unit must be marked with permanent marker to identify the handing of the unit.



EXTRACT FROM DWELLING - This duct port is connected to the ducting that carries waste air from the 'Wet Rooms' to the HRV unit.



SUPPLY TO DWELLING - This duct port is connected to the ducting that carries the fresh warmed air to the habitable rooms from the HRV unit.



TO ATMOSPHERE - This duct port is connected to the ducting that carries the waste air to outdoors from the HRV unit.



FROM ATMOSPHERE - This duct port is connected to the ducting that carries fresh outdoor air to the HRV unit.

Condensate Drain

The unit's Condensation Drain Pipe must be fitted and connected to the dwelling's foul water drainage system in accordance with the relevant building regulations. Condensation Drain Pipe Is attached via a 22mm compression fitting.

The Condensate Drain:

- Must incorporate a suitable trap, which must act as an air lock, ie must be sealed.
- Must be adequately secured along it's length.
- Must be insulated if any part of the pipe passes through a unheated void or a space which could fall below 10°C.
- Must be installed to have a 3 to 5° fall from the unit.
- Titon recommend the use of a diaphragm type waste valve, in place of a conventional 'wet' trap which could dry out; Such as a 'Hepworth HepvO® Hygienic self sealing (waterless) plastic waste valve' recommended as an alternative to traditional U-Traps (BRE certificate no. 042/97).
- If using a wet U-trap please ensure the U-trap has been filled to a suitable level of water to avoid any air locks.

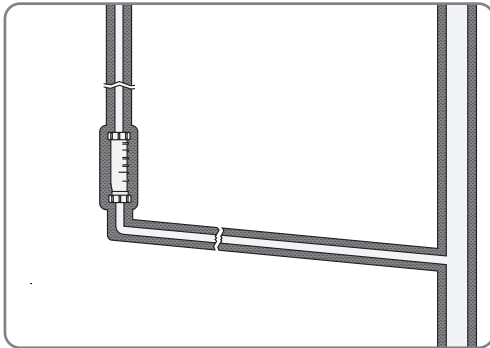

Insulated Self Sealing (waterless) Trap and Waste

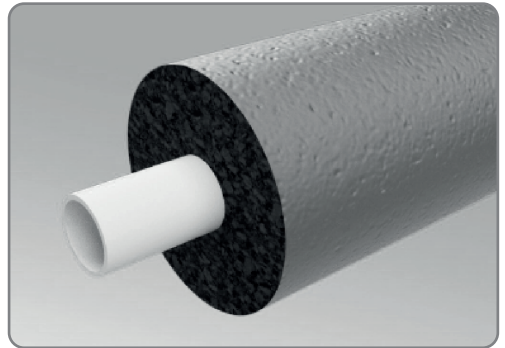

Insulated Condensate Drain

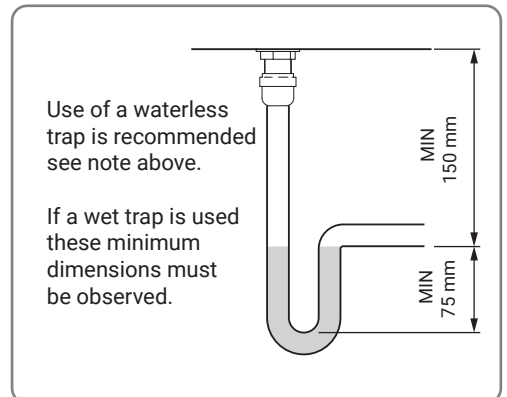

Wet Condensate Drain Minimum Dimensions

Ducting Connections

The MVHR unit has a labels with the icons indicating which port is which.

Read and observe the Warnings, Safety Information and Guidance.

It is very important that ducting is connected to the correct ports in line with the icons below.



EXTRACT FROM DWELLING - This duct port is connected to the ducting that carries waste air from the 'Wet Rooms' to the HRV unit.



SUPPLY TO DWELLING - This duct port is connected to the ducting that carries the fresh warmed air to the habitable rooms from the HRV unit.



TO ATMOSPHERE - This duct port is connected to the ducting that carries the waste air to outdoors from the HRV unit.



FROM ATMOSPHERE - This duct port is connected to the ducting that carries fresh outdoor air to the HRV unit.

Port Designations

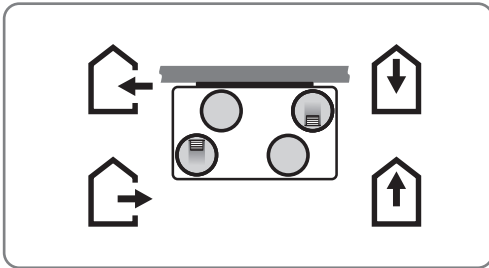

Left Hand Units' Duct Connections

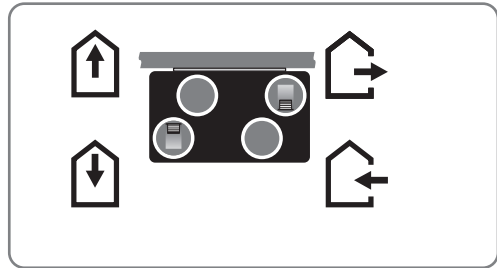

Right Hand Units' Duct Connections

Wiring

Wiring Access

All wiring must conform to current I.E.E. Wiring Regulations and all applicable national standards and Building Regulations.

Read and observe the Warnings, Safety Information and Guidance.

All units use the same Electronics Terminal Enclosure. The compartment has two removable lids. The front lid must always be removed before the rear lid; both lids are fixed by four screws.

All wiring must be routed into the electronics compartment using cable glands or similar.

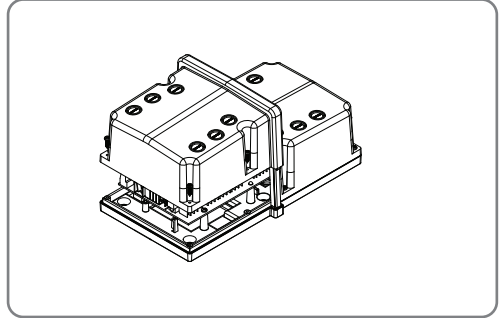

Electronics Terminal Enclosure

Supply

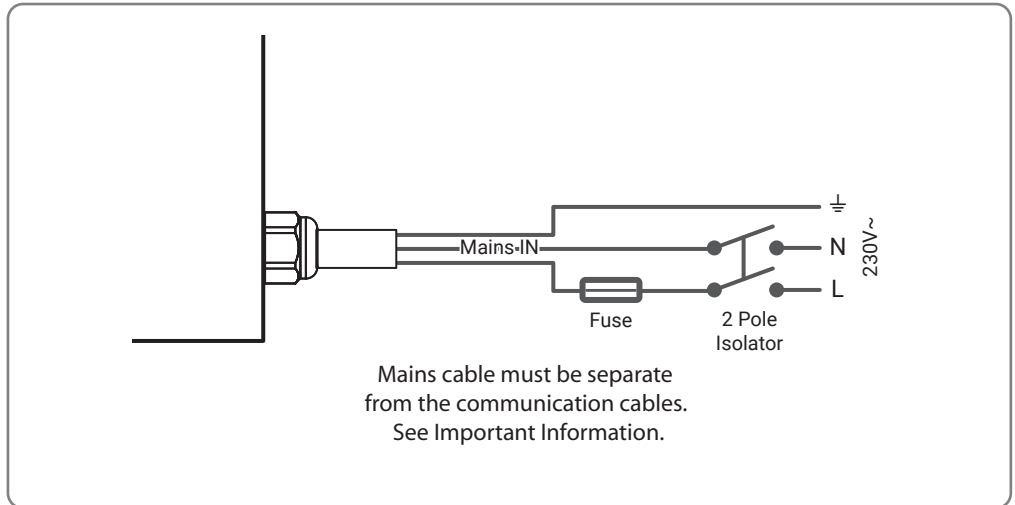

Supply Wiring

Switching & Controls

Volt-free control of SUMMERboost® using one way latching switch.

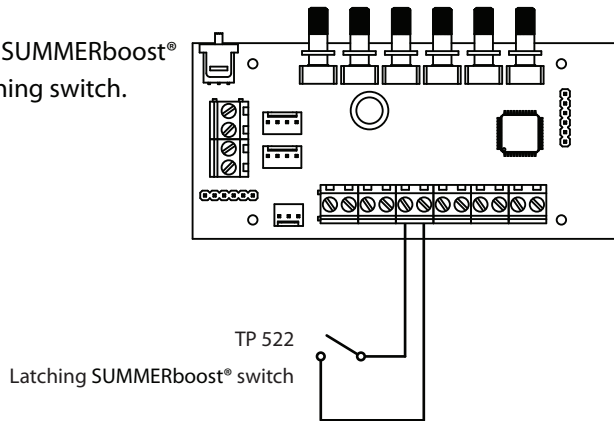

SUMMERboost® switch connection ref EE178

Volt-free boost switching of MVHR controller PCB using single-pole switches TP 502, TP 503, TP 507 and / or TP500 / TP501 humidistat.

There is maximum of 10 single pole switches or humidistats that can be used.

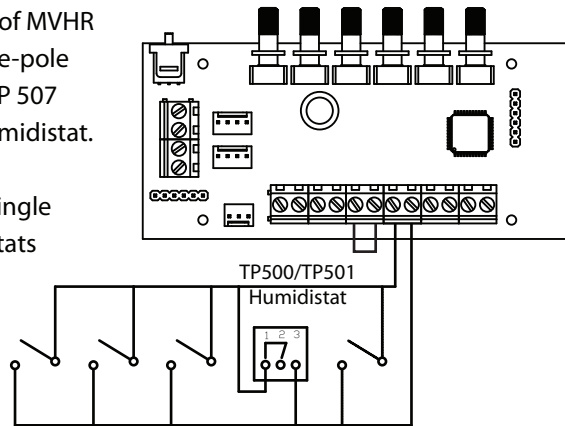

Boost switching and humidistat connection ref EE173

Volt-free setback switching of MVHR controller PCB using single-pole latching switch and / or volt-free normally open relay contacts.

To avoid the unit being inadvertently left in Setback Mode, it is recommended that only one latching switch is fitted.

Volt-free setback switch or normally open relay contacts

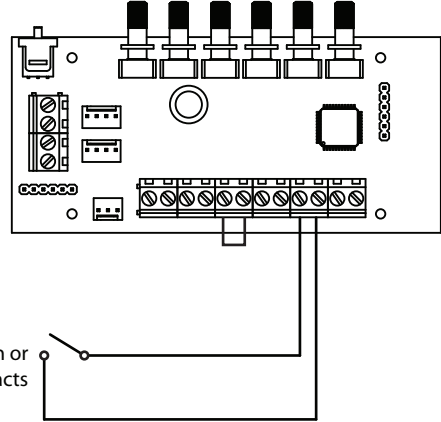

Setback Mode switching and connection ref EE177

SWITCH POSITIONS

- 1 - Setback Speed
- 2 - Continuous Speed
- 3 - Boost Speed

TP 508
Three position rotary switch

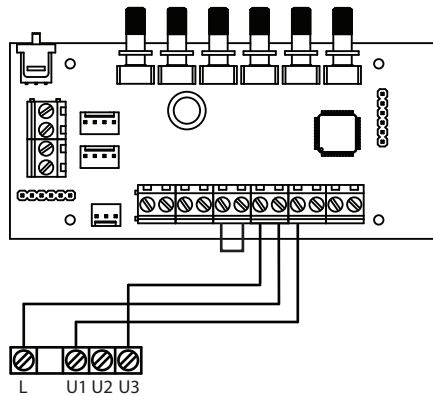

Three Position Rotary Switch TP 508 switching and connection ref EE175

SUMMERboost® Link Wire must be removed to enable SUMMERboost®.

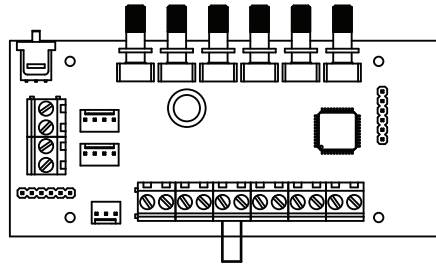

SUMMERboost® Link Wire

SUMMERboost® Link Wire

Volt-free control of SUMMERboost® using room thermostat.

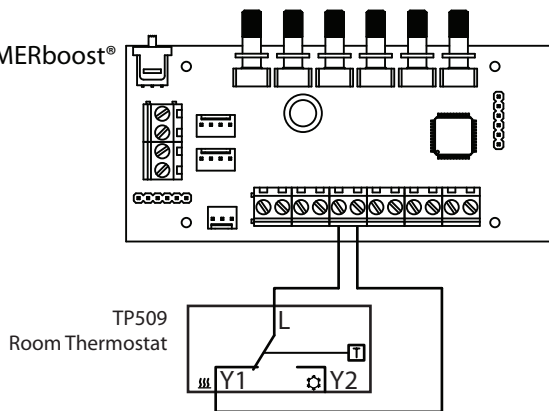

SUMMERboost® thermostat connection ref EE178

Commissioning

Commission with built in Controls

The fan speeds of the Titon HRV *Q Plus* will require adjustment to ensure the flow rates achieved provide adequate ventilation. The Titon HRV *Q Plus* has 2 standard fan speed settings Continuous Speed and Boost Speed.

The Continuous Speed and Boost Speed are programmed by placing the controller into Program Mode via the Program/Run Switch and changing the position of rotary controls.

When applying power for the first time, the unit can take up to four minutes to start operating.

Prior to the first commission set Continuous Speed rotary controls to minimum and Boost Speed rotary controls to maximum or reset the controller.

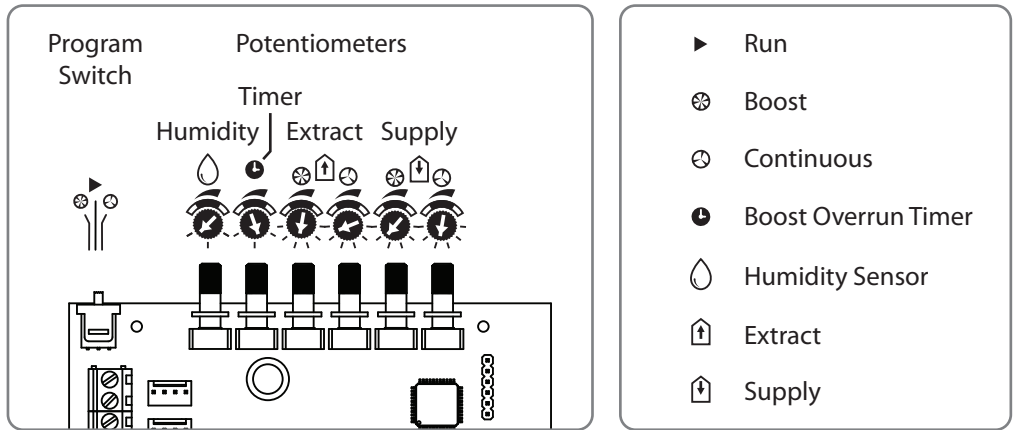

Control Identification

Control Parameters

- The Boost Speed cannot be set lower than the Continuous Speed.
- The Continuous Speed cannot be set higher than the Boost Speed.
- All switching inputs are disabled when the Program/Run Switch is in Continuous or Boost positions.
- Speed control rotary controls are disabled when the Program/Run switch is in centre Run position.

For the commissioning settings to be stored the unit needs to be powered up.

Continuous Supply & Extract Speeds:

1. Move Program/Run Switch to Continuous position.
2. Rotate supply fan Continuous Speed rotary control to achieve required supply continuous air flow.
3. Rotate extract fan Continuous Speed rotary control to achieve required extract continuous air flow.
4. Return Program/Run Switch to centre position to exit commissioning.

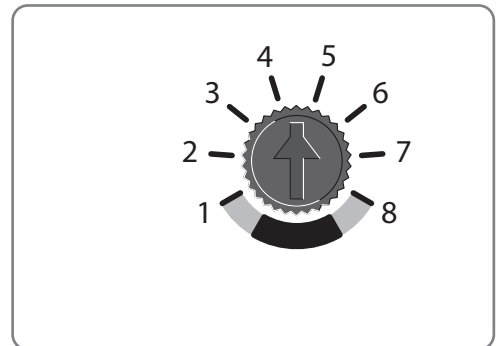

Commissioning Pot positions

Boost Supply & Extract Speeds:

1. Move Program/ Run Switch to Boost position.
2. Rotate supply fan Boost Speed rotary control to achieve required supply boost air flow.
3. Rotate extract fan Boost Speed rotary control to achieve required extract boost air flow.
4. Return Program/Run Switch to centre position to exit commissioning.

Boost Overrun

Boost Overrun Timer is variable between 0 and 60 minutes. Use the rotary controls to change overrun time. Boost Overrun adjustment can be done at any time without the need to move the Program/Run Switch

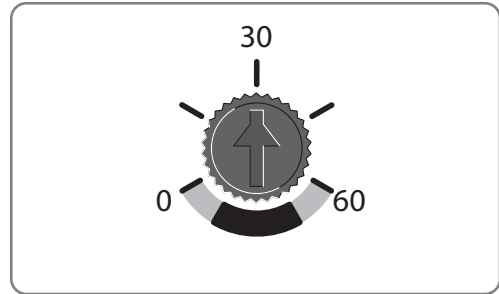

Humidity Sensor

The Humidity Sensor's trigger point is variable from 55%RH to 85%RH. Use the rotary control to change the trigger point. Humidity Sensor adjustment can be done at any time without the need to move the Program/Run Switch.

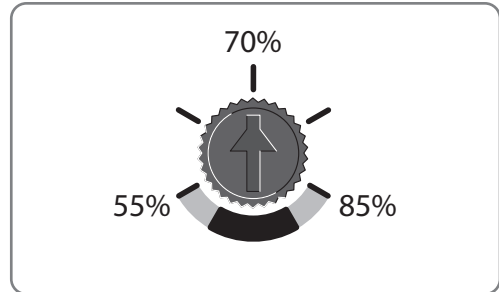

Controller Reset

Following a controller reset the ventilation system will need to be fully commissioned.

The procedure to reset the Titon HRV *Q Plus* controller is a simple three step operation. The unit will need to be powered up during the reset procedure.

1. Rotate the Supply and Extract Continuous Speed potentiometers fully anti-clockwise.
2. Rotate Supply and Extract Boost Speed potentiometers fully clockwise move the Run/Program Switch from the Run position to the Continuous position, from the Continuous position to the Boost position and back to the Run position. To ensure that the reset switch movements are registered by the controller wait two seconds between each switch movement. Controller reset is now complete.

Hardware Reset

Certain conditions (repeated supply interruptions etc.) can activate the automatic motor protection mode. Whereby the fan motors are prevented from operating. This requires a hardware reset to return the unit to normal operating mode, to achieve this power to the unit should be switched off for 5 minutes, restoring the power after this time will reset the hardware of both the motor and PCB. Commissioning settings are not affected during a hardware reset.

Maintenance

Routine Maintenance

All ventilation units require periodic maintenance. Routine maintenance, apart from filter changes, must only be carried out by a suitably qualified and competent person.

WARNING: The unit uses a ~230V supply and contains rotating mechanical parts.

ISOLATE the unit from mains power supply and allow sufficient time for all moving parts to stop before undertaking any Servicing or Maintenance.

The unit may be supplied with multiple live supplies if a Duct Heater is fitted or uses switched live for Boost Speed control.

Cleaning Exterior

For best results use a clean damp cloth. Do not use abrasive cleaners, solvents or any other fluids.

Cleaning Interior

For best results:

1. Slide out the Filters.
2. Carefully remove any dust from face of heat exchanger, interior of the unit and the Bypass using a vacuum cleaner

Do not use water or any other fluids

HRV1.35, 1.6, 4 & 4.25

Front Cover Removal

3. ISOLATE the unit from mains power supply and allow sufficient time for all moving parts to stop
4. Loosen the two corner screws located on the bottom front of the unit
5. Completely remove the centre screw
6. Completely remove the Front Cover by pulling it away from the unit at the bottom and lifting

Cover replacement is the reverse of the above steps. Ensure it is securely located at the top before tightening screws.

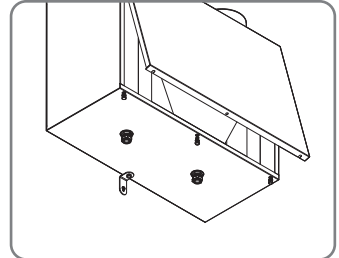

Condensate Tray

If the Condensate Tray is split a replacement must be ordered and fitted.

HRV1.35 Q Plus	Part No. XP40042M
HRV1.65 Q Plus	Part No. XP4010649M
HRV4 & HRV4.25 Q Plus	Part No. XP4011570

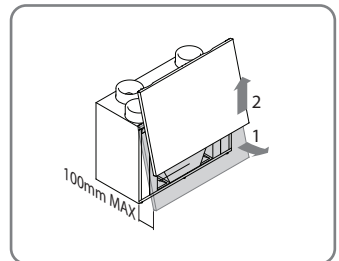

Filter Replacement

Filters should be replaced at least annually, or more regularly dependent on environmental conditions. Filters should be replaced with like for like components. The connected controller will indicate filter change required in line with the Filter Change Interval settings. Replacement filter part numbers below.

Model	G3 Filter Set Both faces white	G4 Filters Set One face white, one face blue	G4 Filters Set	F7 Single Filter	G4 & F7 Filter Set
HRV1.35 <i>Q Plus</i>	XP40032	XP46022			
HRV1.6 <i>Q Plus</i>	XP2011902	XP2011903			
HRV4 <i>Q Plus</i>			XP2011629	XP2011630	XP2011754
HRV4.25 <i>Q Plus</i>					

Following filter replacement the HRV controller's Filter Warning should be reset, refer to Product Manual of controller for details.

HRV1.35, 1.6, 4 & 4.25

The Filters are available in different grades G3, G4 & F7. Filter media should be replaced like for like. Filter Part numbers in table above.

To replace filters.

1. Remove Filter Covers.
2. Slide out Filters make note of any arrows on the filters.
3. Replace Filters by carefully sliding in the replacement filters. Ensure that filters are replaced in the same orientation as they were removed.
4. Replace Filter Covers.

Installed by:

In the event of any queries please contact the system installer.
Ensure this booklet is passed to the householder once installation & commissioning of the ventilation system is complete.

This Product Manual must be kept in the Home Information Pack.



MARKETING DIVISION

894 The Crescent, Colchester Business Park, Colchester, CO4 9YQ

Tel: +44 (0) 1206 713800 Fax: +44 (0) 1206 543126

Email: ventsales@titon.co.uk Web: www.titon.com