

SR700 SRHRV Fan

TP600

### Single Room Heat Recovery Ventilation Fan Unit



SRC1 Controller

TP590

### Single Room Heat Recovery Ventilation Controller Unit

Product Installation Manual

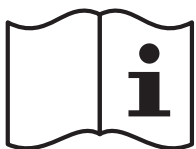

# Warnings, Safety Information and Guidance

## Important Information

### Read these instructions fully before the installation of this appliance

1. Installation of the appliance and accessories must be carried out by a qualified and suitable competent person and be carried out in clean, dry conditions where dust and humidity are at minimal levels.
2. This manual covers the installation of the Single Room Heat Recovery Ventilation SR700 SRHRV Fan Unit and SRC1 Controller Unit.
3. All wiring must conform to current I.E.E. Wiring Regulations and all applicable standards and Building Regulations.
4. Inspect the appliance. If damaged, it must be replaced by the manufacturer or their service agent in order to avoid a hazard.
5. The appliance must be connected to a local all pole isolation switch with a contact separation of at least 3mm.
6. The SRC1 Controller Unit is suitable for 220-240V ~ 50-60Hz single phase with a fuse rating of 3A.
7. Control & communication cable - Titon recommends the use of unshielded CAT5e cable to comply with EMC directives.
8. Control & communication cables should not be placed within 50mm or on the same metal cable tray as any mains lighting or power cables.
9. The unit must be stored in a clean and dry environment.
10. Do not install the appliance in areas where the following may be present or occur:
  - o Excessive moisture, oil or grease laden atmosphere;
  - o Corrosive or flammable gases, liquids or vapours;
  - o Ambient temperatures above 40°C or below -5°C;
  - o Humidity levels above 90%;
  - o A wet environment.
11. The appliance is not suitable for installation to the exterior of the dwelling.
12. This appliance can be used by children aged from 8 years and above and persons with reduced physical, sensory or mental capabilities or lack of experience and knowledge if they have been given supervision or instruction concerning use of the appliance in a safe way and understand the hazards involved. Children should be supervised to ensure that they do not play with the appliance. Cleaning and user maintenance shall not be made by children without supervision.
13. Ensure that external grilles are located away from any flue outlet, in accordance with relevant Building Regulations.
14. The unit must not be connected to a tumble dryer or a cooker hood.
15. Precautions must be taken to avoid the back-flow of gases into the room from an open flue appliance.
16. Ensure ducting is free from debris and blockages before switching on the units.
17. Before cleaning, power down the ventilation system and wait sufficient time for the Fans to stop rotating before starting cleaning.
18. When handling unit care must be taken as the unit is unbalanced.

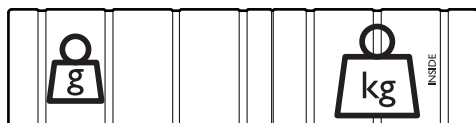

<b>Warnings, Safety Information and Guidance</b>	
Important Information .....	2
<b>Product Information</b>	
Benefits and Features .....	4
Packaging Contents .....	5
SR700 Fan Unit .....	5
SRC1 Controller Unit .....	5
Dimensions & Component Identification .....	5
<b>Installation</b>	
SRHRV Fan Unit .....	7
Hole Preparation .....	7
Vent Tube .....	8
External Louvre .....	9
Internal Bezel .....	10
Internal Components .....	11
Diffuser .....	12
<b>Wiring</b>	
Fans .....	13
Connection .....	13
SRC1 Controller Unit .....	14
Mains .....	14
Sensors .....	15
Sensor Options .....	15
<b>Commissioning &amp; Controls</b>	
Operation .....	16
Heat Recovery Mode .....	16
Cross Ventilation Mode .....	16
Fan Speeds .....	16
Fan setting 1 (Large dwelling) .....	16
Fan setting 2 (Small dwelling) .....	16
Sensor Mode .....	16
Sleep Mode .....	17
Filter Monitoring .....	17
<b>Service Menu</b>	
Errors .....	19



When this document is viewed as a PDF the headings & sub headings on this page are hyper links to the content. Additionally the page numbers in this document are hyper links back to this contents page.

## Product Information

Designed to be used in pairs and in conjunction with a SRC1 the SR700s create a balanced decentralised ventilation system with heat recovery. As part of a system multiple units provide continual air circulation for your home, extracting stale moist air and replacing it with warmed fresh air from outside.

The system provides an easily installed and maintainable solution for removing internal condensation and eliminating mould growth within the home. Unlike regular extractor fans that waste 100% of heat that passes through them from the home, the SR700 system will recover up to 94%, based on in house testing, of wasted heat. When used as part of a whole house system it can be used to recover heat or provide continuous fresh air without heat recovery.

## Benefits and Features

- Achieves 20Pa back pressure as per BS EN 13141-8:2014.
- 6 SR700s can be connected to one SRC1.
- Easy to maintain.
- Low noise and vibration level due to expanded polypropylene housing.
- Low profile wall mounted fascia.
- No additional duct work required.
- Sleep mode sets the unit to its function at its slowest running. Returning to normal function after a set time.
- Humidity mode provides ventilation rates suitable for when dwellings are unoccupied.
- Intensive ventilation (Manual) to quickly remove any odours that are present.
- Intensive ventilation (Automatic) to quickly remove excessive amounts of moisture and dangerous levels of Carbon dioxide in the dwelling – (optional sensor required).
- Cross ventilation mode for a constant flow of fresh cool air through the house without heat recovery.
- Suitable for wall thicknesses of between 305mm to 700mm.
- The ventilation rate for the SR700 can be configured for both large and small dwelling via the fan settings option in the service menu.

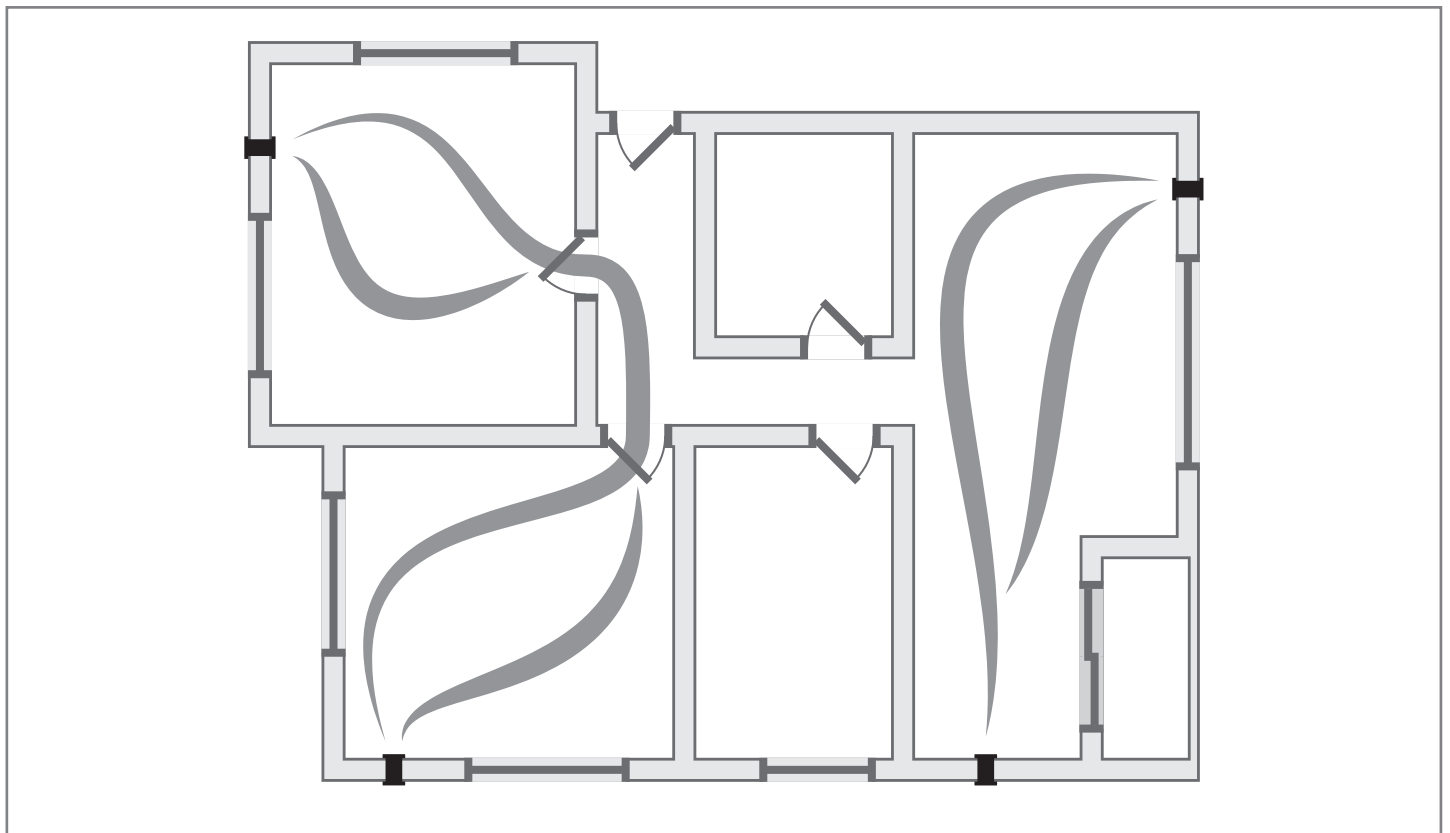

System Layout

## Packaging Contents

Inspect the units when taking delivery. Check the units for damage and that all accessories have been supplied.

### SR700 Fan Unit

Package supplied with:

- SR700 Fan unit x 1;
- Product Installation Manual x 1.

**Any shortages or damage must be immediately reported to the supplier.**

## Dimensions & Component Identification

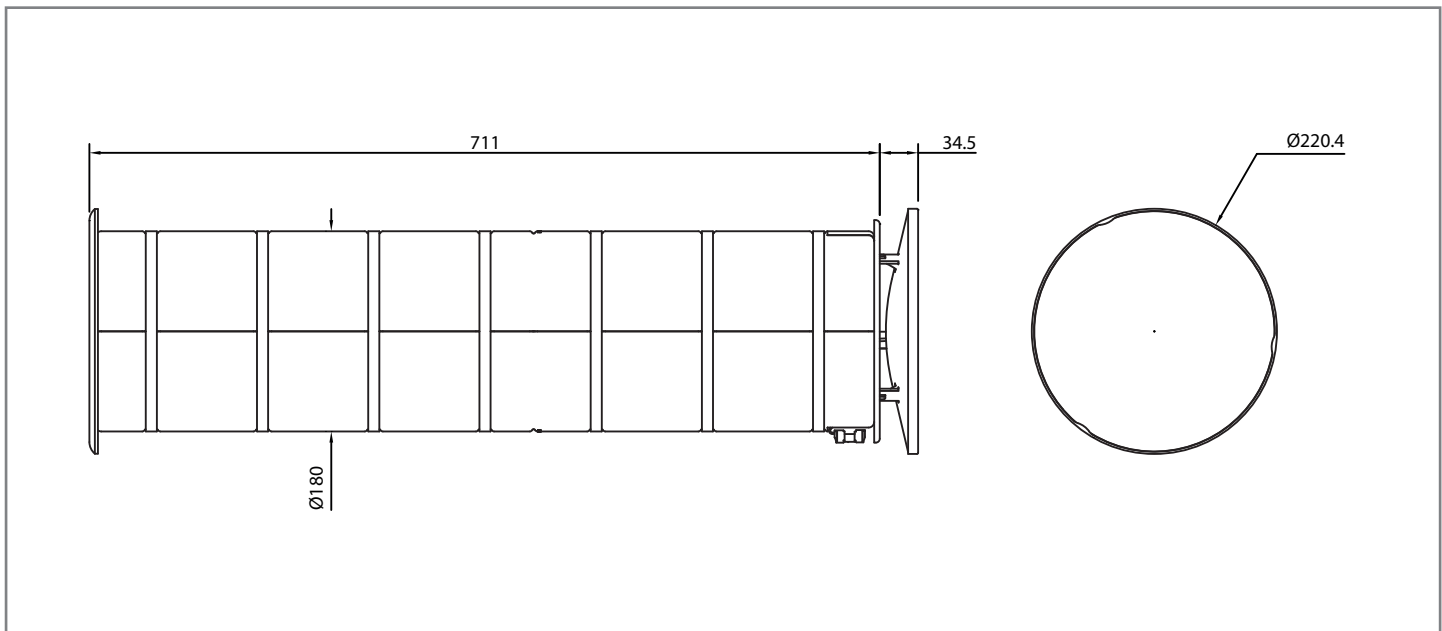

Fan Unit

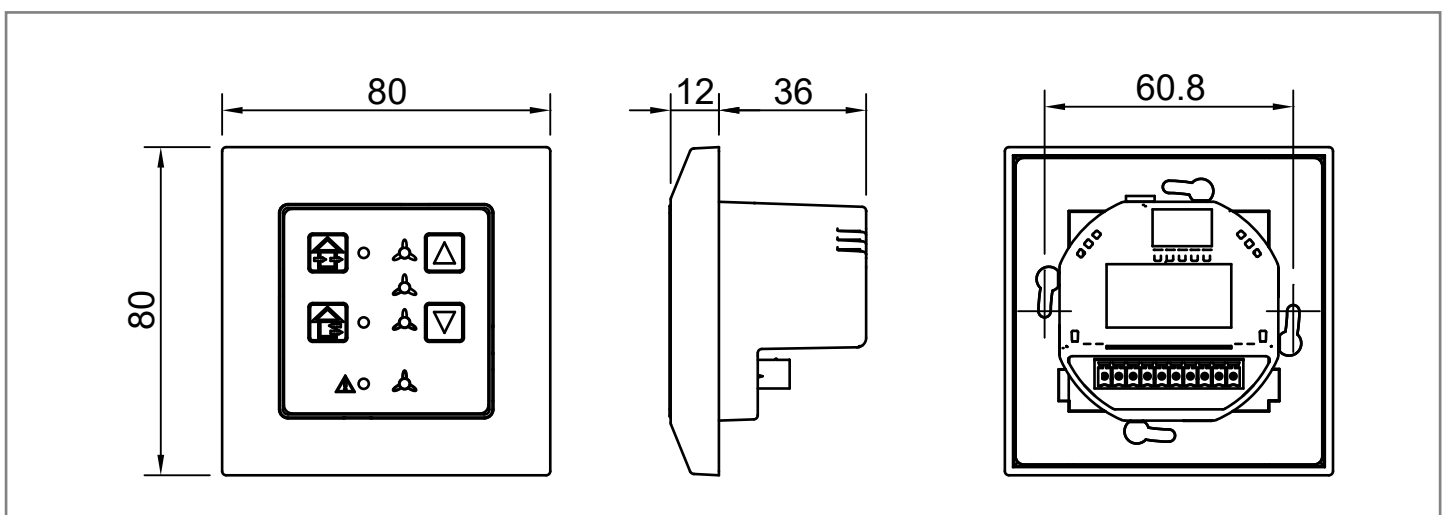

Controller Unit

# Installation

No.	Component
1	Diffuser
2	Bezel
3	Wiring Aperture Cover
4	Spring Steel Clip
5	Air Filter

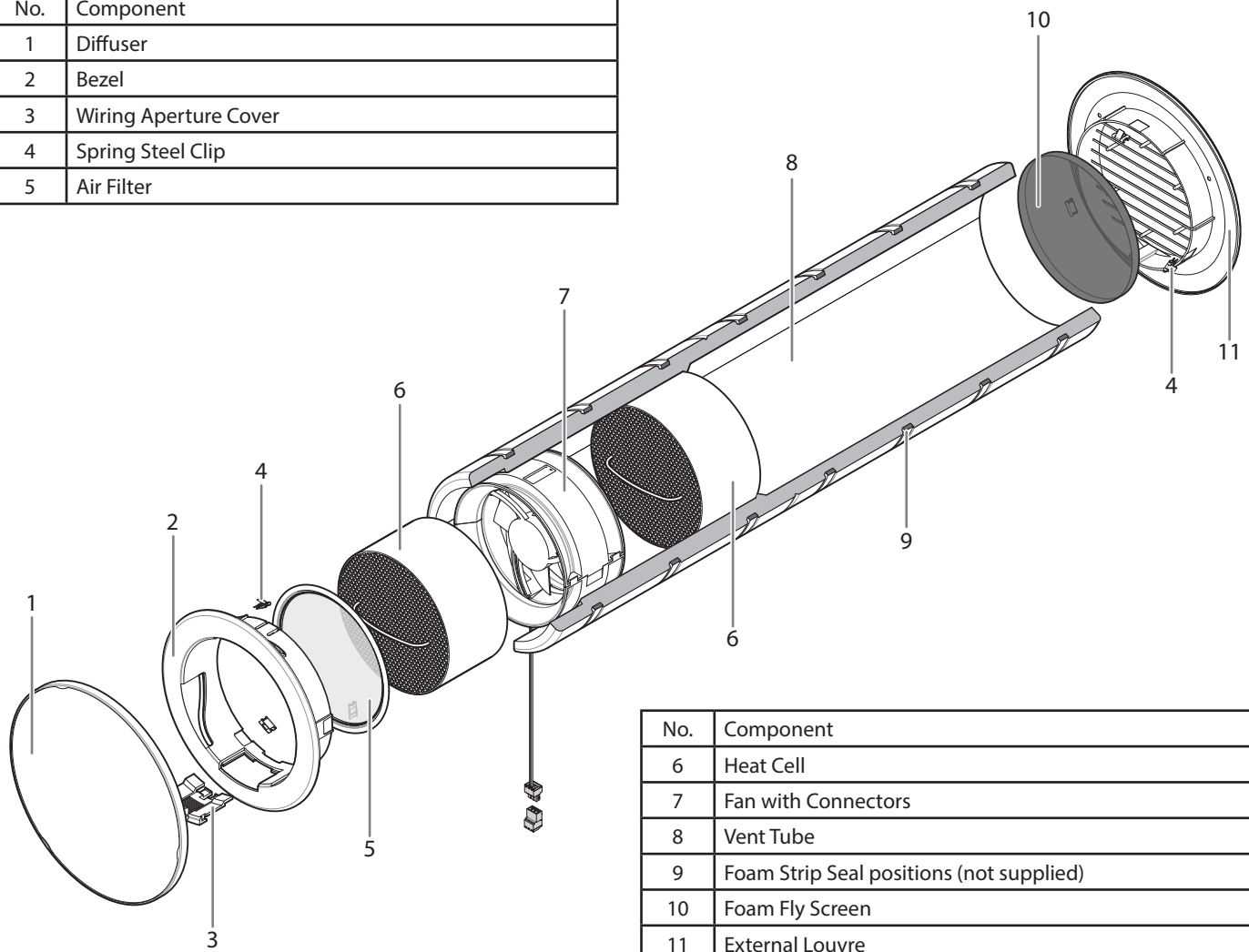

No.	Component
6	Heat Cell
7	Fan with Connectors
8	Vent Tube
9	Foam Strip Seal positions (not supplied)
10	Foam Fly Screen
11	External Louvre

SRHRV Fan Unit -Components

## SRHRV Fan Unit

Read and observe the guidance & safety notices listed in Warnings, Safety Information and Guidance .

- The Titon SRHRV Fan unit is designed to be mounted through a wall with a thickness between 305mm & 700mm.
- Consider the positioning of electrical services when siting the Fan Units and Controller.

### Hole Preparation

1. Position SRHRV Fan unit(s) ensuring clearances required between adjacent wall(s), window(s) and ceiling are adhered to.
2. Drill  $\text{Ø}182\text{mm}$  hole through the wall with a fall angle of  $1^\circ$  to  $2^\circ$  towards the outside .

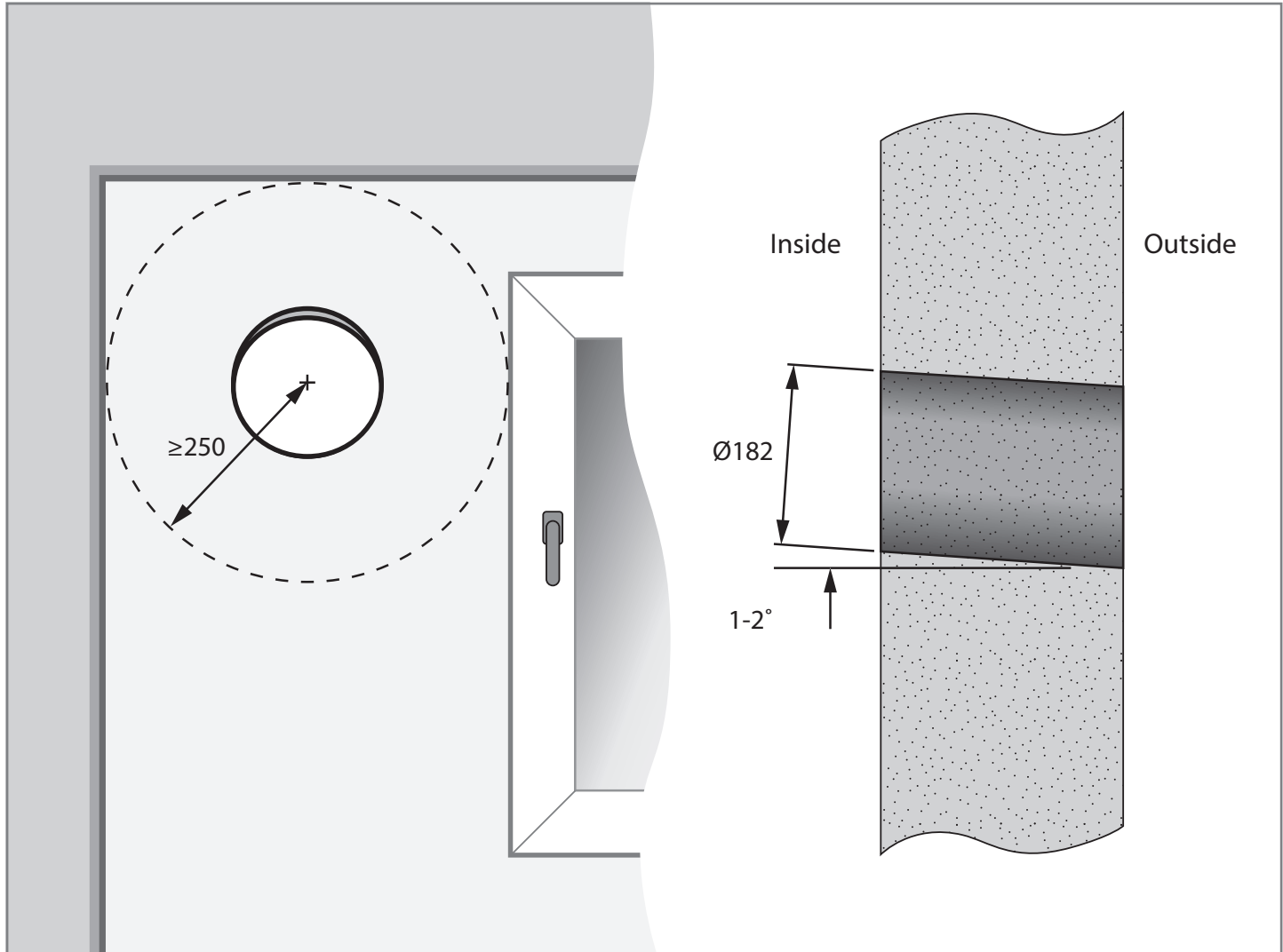

Hole Preparation

## Vent Tube

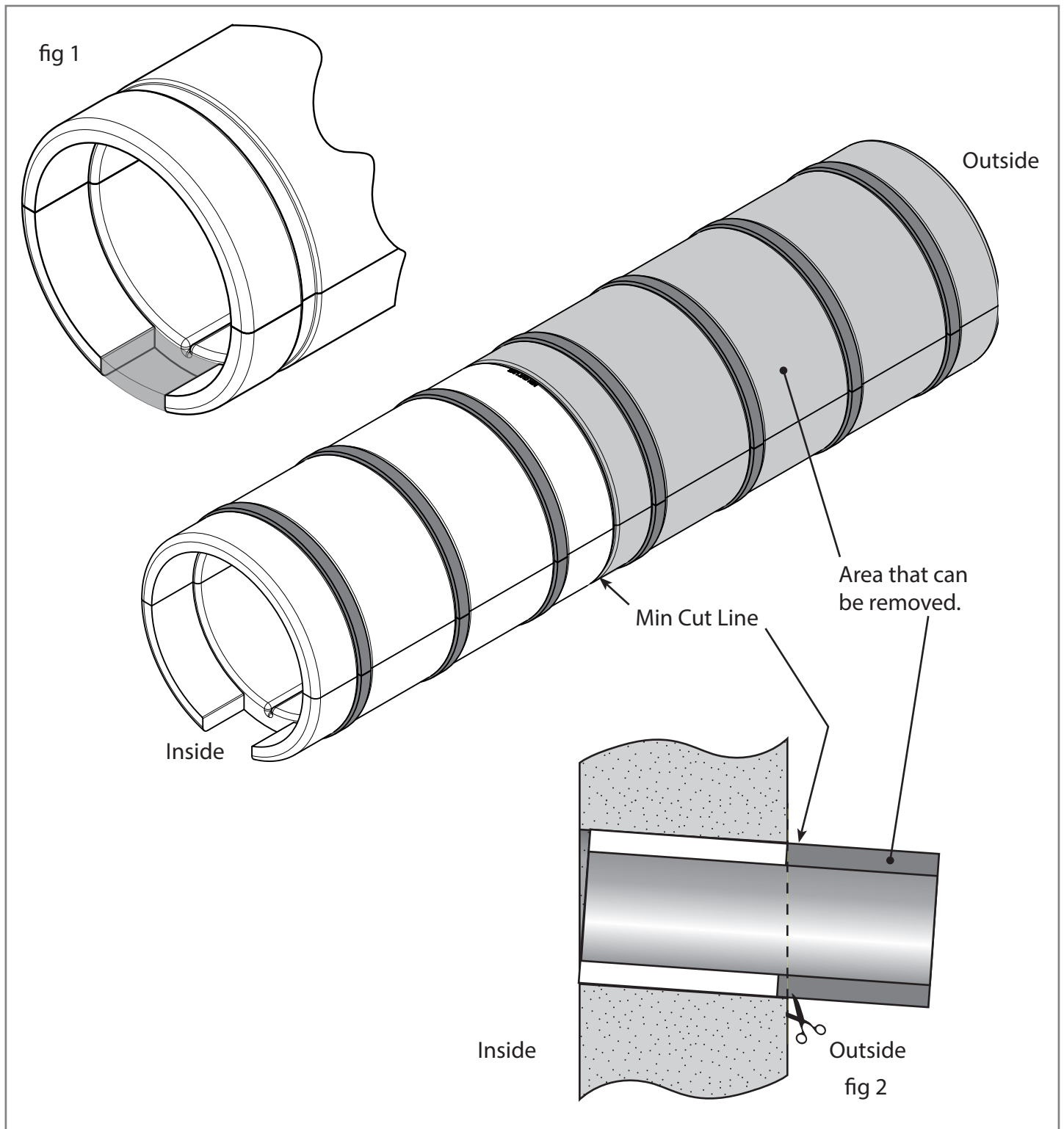

Installation, Cutting & Orientation

3. Prepare Vent Tube. Cut out one of the Wiring Pockets Using a sharp blade, cut out the material highlighted to create an aperture to accommodate the 12v fan connection, fig 1.
4. Fit Seals. Fit minimum of three self-adhesive expanding foam strips (not supplied). in to the channels around the diameter of the vent tube. Ensure channels at either end of the tube are occupied.
5. Slide Vent Tube into hole, ensure that the internal lower edge of the Vent Tube is flush with the finished interior surface and that the Wiring Pocket is orientated to suit the wiring.
6. Trim excess Vent Tube flush with the exterior finished surface, fig 2.

## External Louvre

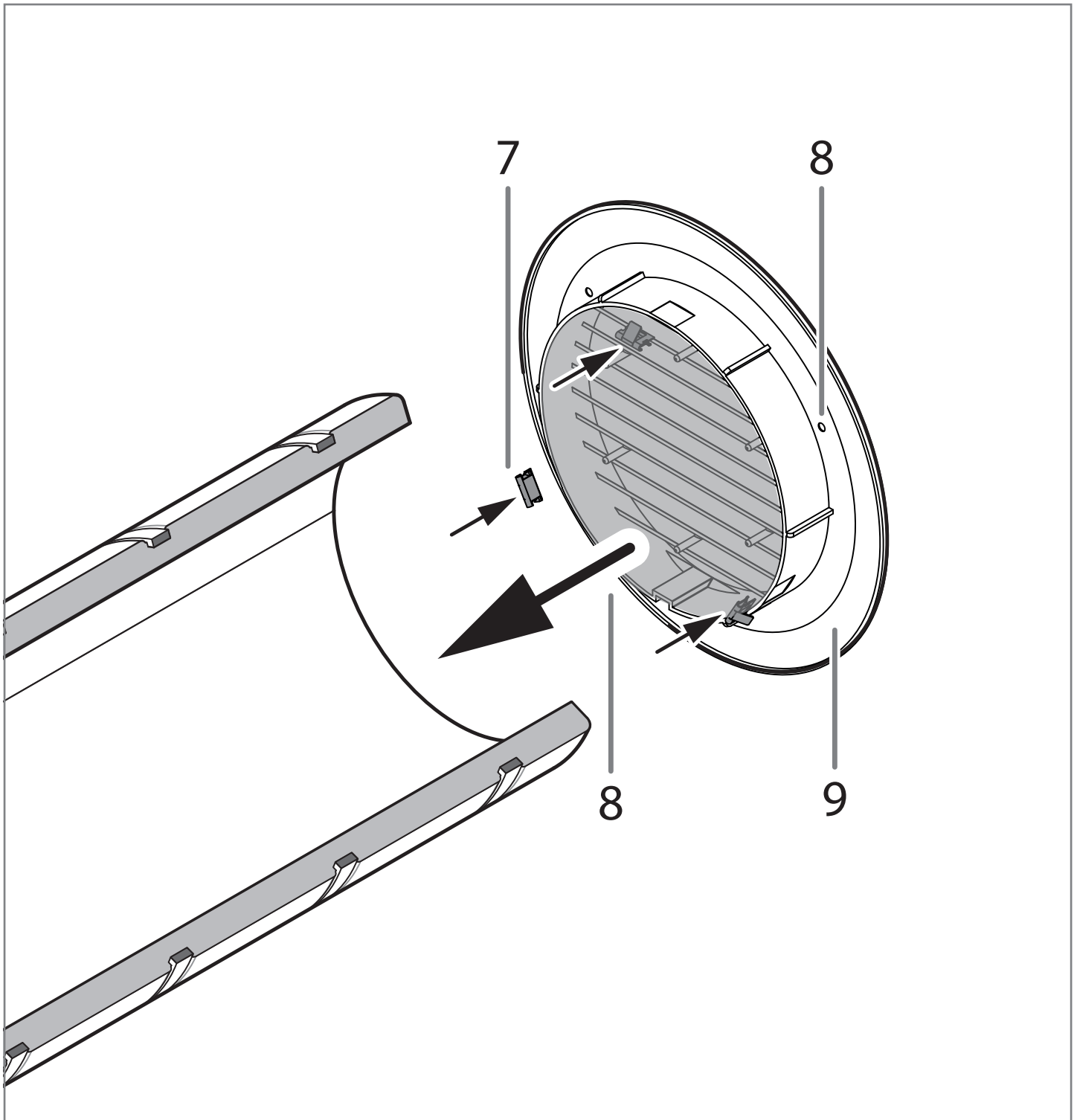

External Louvre, Screw Ports and Sealant Groove

7. Fit three of the Spring Steel Clips to the positions on the External Louvre.
8. Fit External Louvre. Louvre is a push fit. If screw fixing is desired drill out the three screw ports from the inside to the outside of the External Louvre using a  $\text{\O}4\text{mm}$  drill. Fix the External Louvre to the Vent Tube using three 3.5mm x 32mm Pan Head PoziDriv<sup>®</sup> Self Tapping Screw Form C to DIN 7981C ~ISO 7049 A4 Stainless Steel.
9. The External Louvre also has an area where sealant can be applied to seal the underside of the External Louvre's flange to the surface of the building's exterior finish.

## Internal Bezel

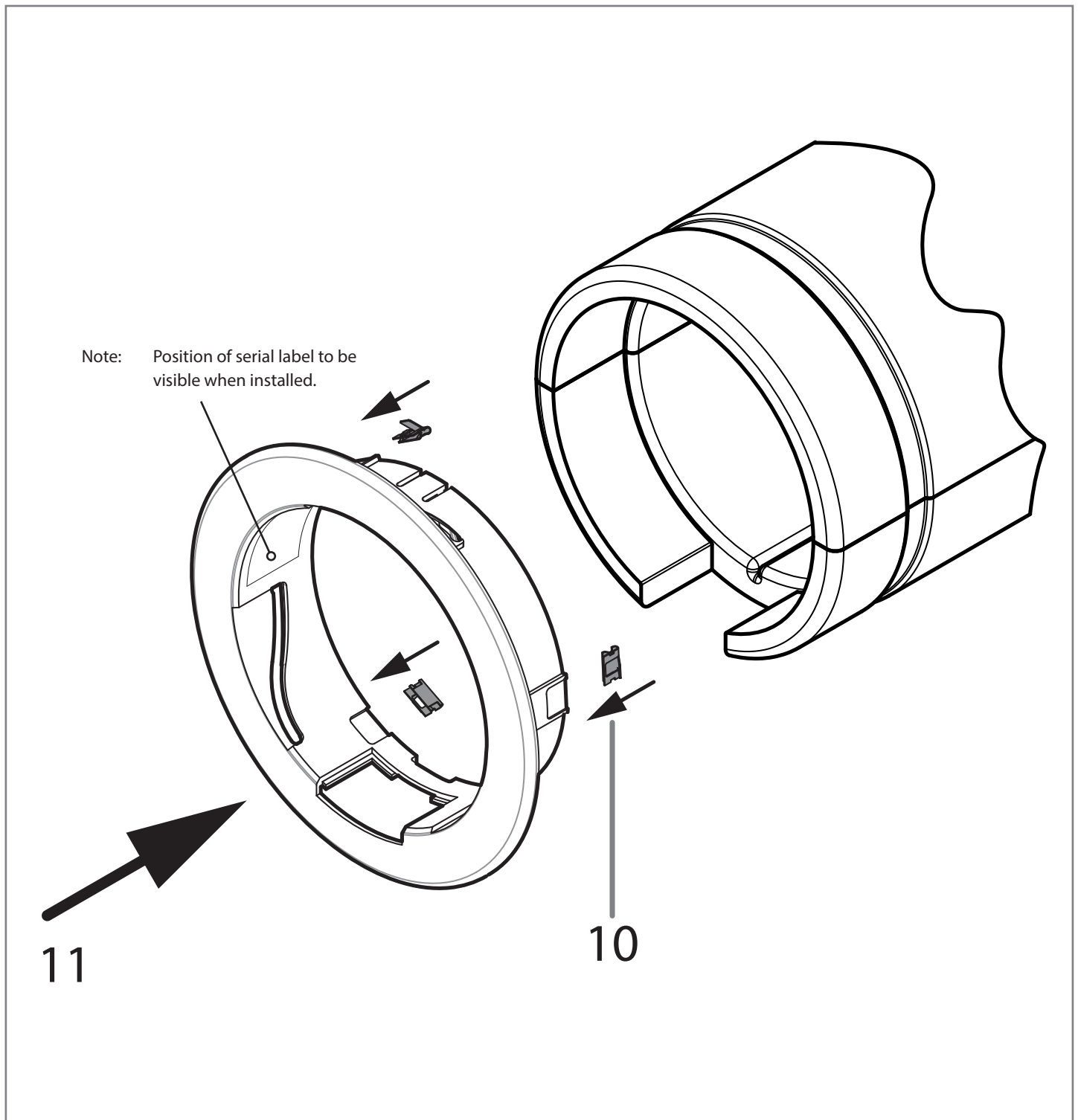

10. Fit the remaining three Spring Steel Clips to the positions on the Internal Bezel.
11. Fit Internal Bezel. Internal Bezel is a push fit into the Vent Tube, when fitting ensure Wiring Aperture is aligned with the Wiring Pocket in the Vent Tube.

## Internal Components

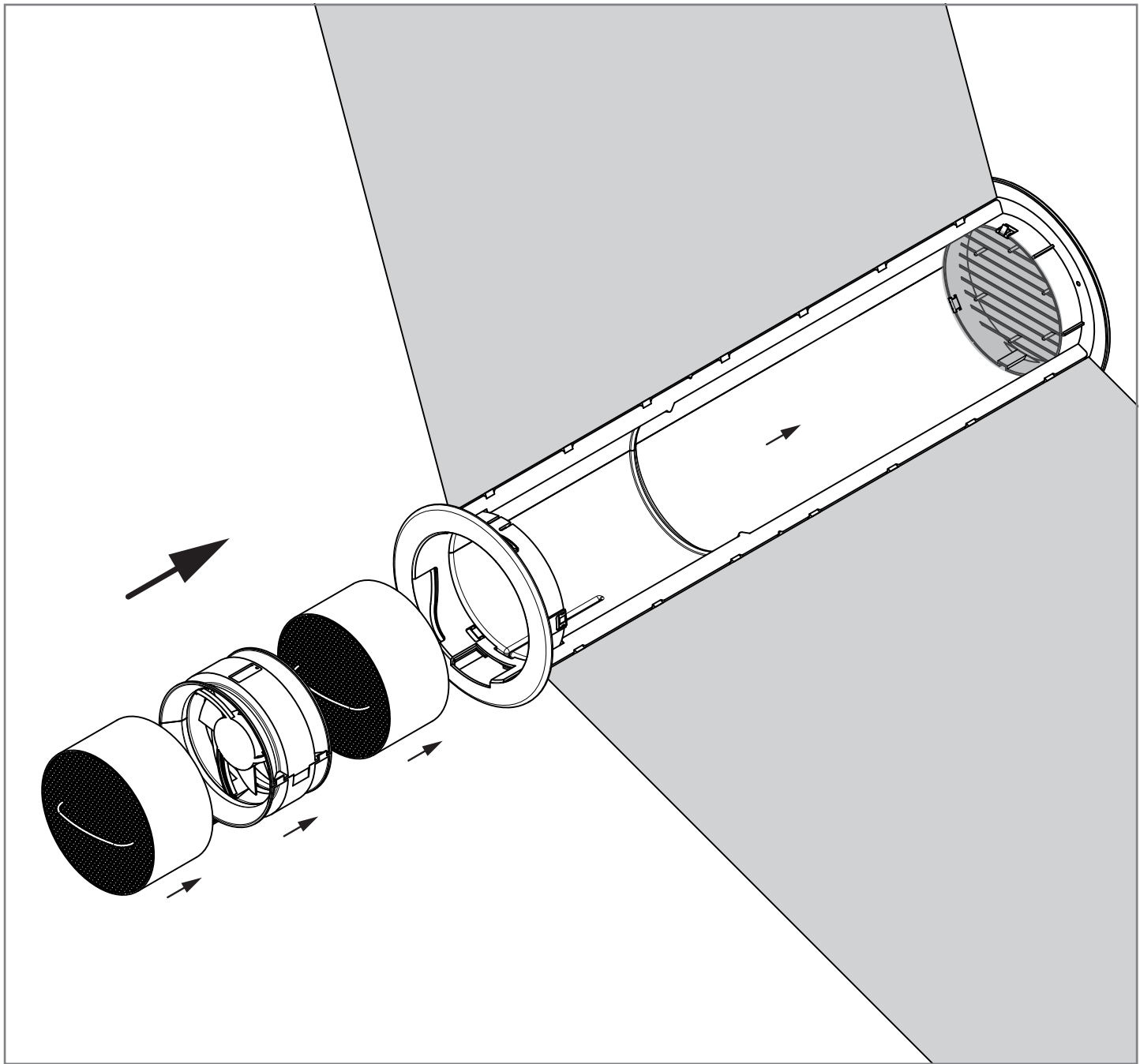

Fit Internal Components

12. Fit the first Ceramic Heat Cell. Slide a Ceramic Heat Cell into the Vent Tube. Ensure the Wire Handle is facing the inside and that the Ceramic Heat Cell is pushed up against the stop in the Vent Tube.
13. Fit the Fan. Slide the Fan into the Vent Tube. Ensure the control wires are pushed into the Cable Groove and the Connection Plug is fed into the Wiring Aperture. Also ensure that the Fan is pushed up firm against the first Ceramic Heat Cell. Orientation of the Fan - Label must face into the dwelling.
14. Fit the second Ceramic Heat Cell. Slide the Ceramic Heat Cell into the Vent Tube. Ensure the Wire Handle is facing the inside and the Ceramic Heat Cell is pushed up against the Fan.

## Diffuser

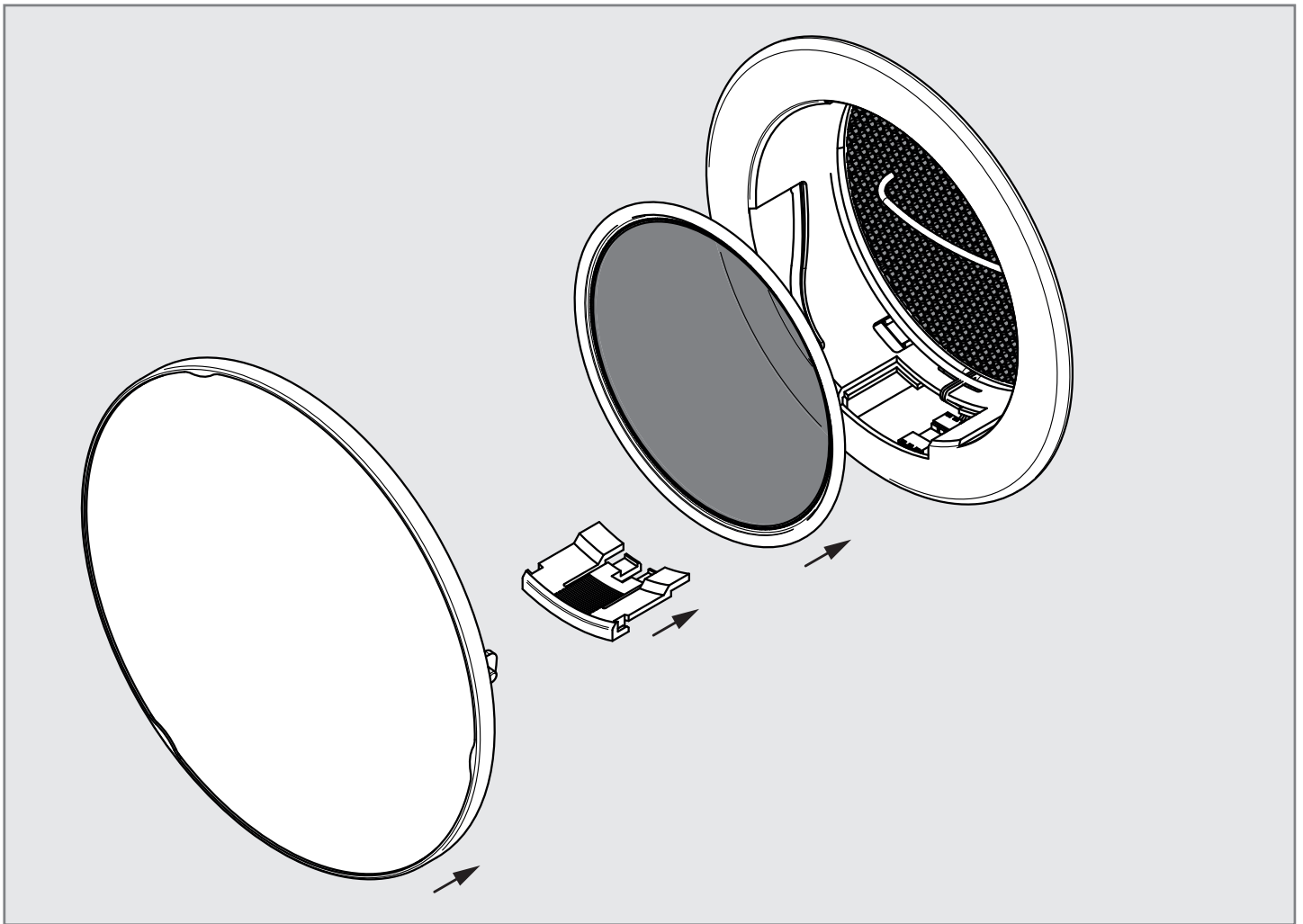

Fit Wiring Cover and Diffuser

15. Connect the Fan Cable. Using the push connector connect the Fan Cable to the Communication Cable, see wiring section for details.
16. Fit the Air Filter, which is held in place by the Wiring Aperture Cover.
17. Fit the Wiring Aperture Cover. Clip the Wiring Aperture Cover in place ensuring the wiring is not strained
18. Fit the Diffuser. Clip the Diffuser to the Internal Bezel ensure that all three clips are engaged and the Diffuser rotates freely from the closed to fully open position. Remove the protective film from face of diffuser.

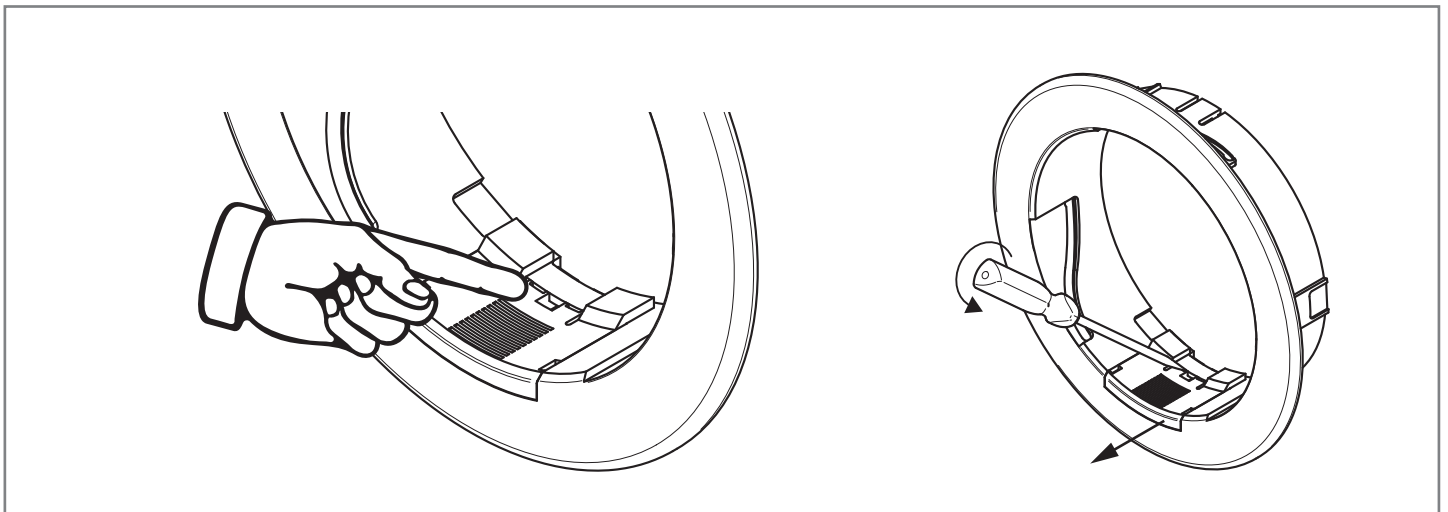

How to remove Wiring Cover

## Fans

### Connection

Connection of Fan Unit(s) to Controller is to be made with specified communication cable. Up to 3 pairs (six fans) can be connected to the controller by connecting multiple cables to each terminal or by using a separate larger capacity connector.

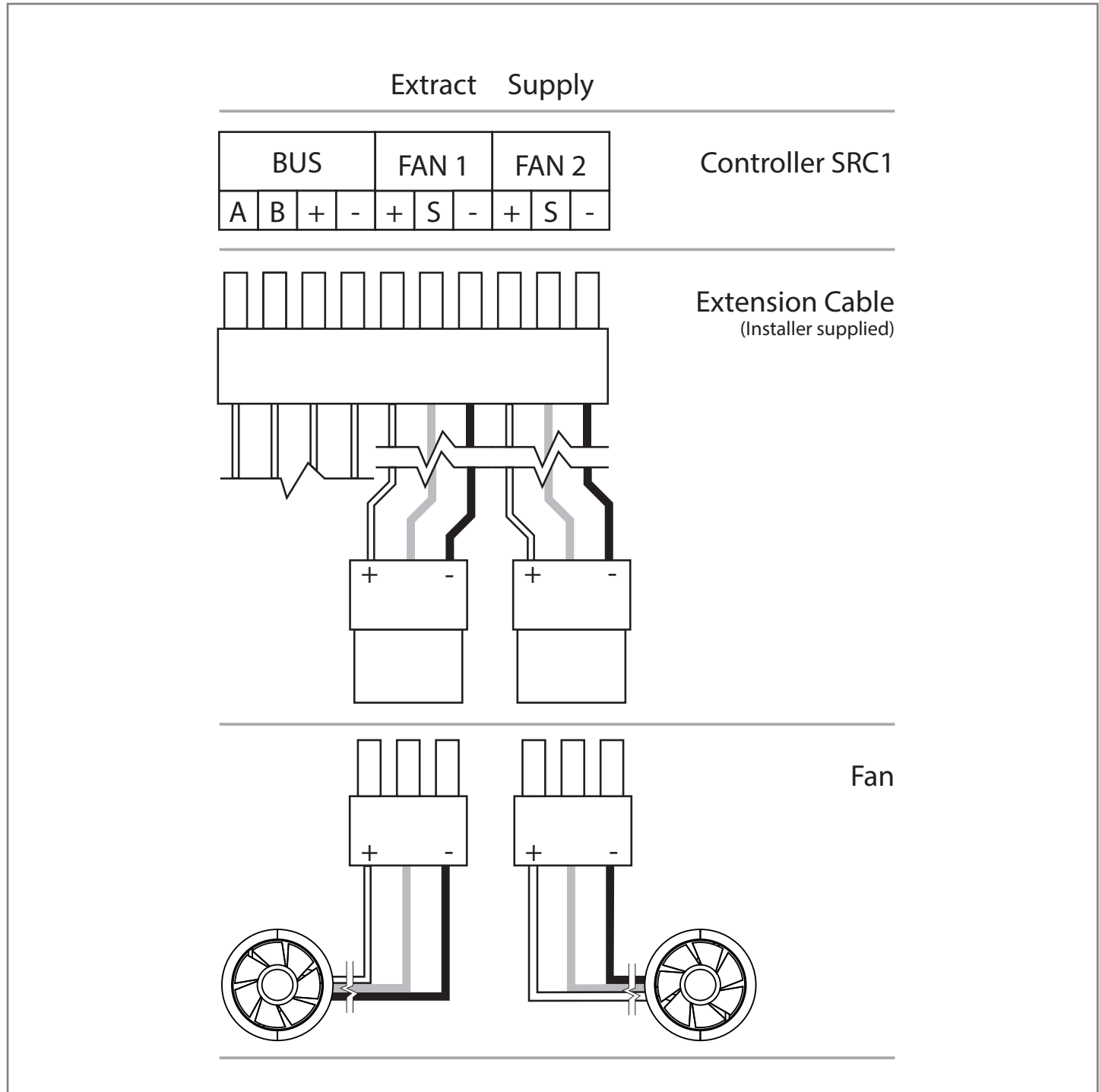

Connect Wiring

## SRC1 Controller Unit

All necessary control components are integrated in this device. The SRC1 Controller is designed to fit into a single flush mounting wall box.

### Mains

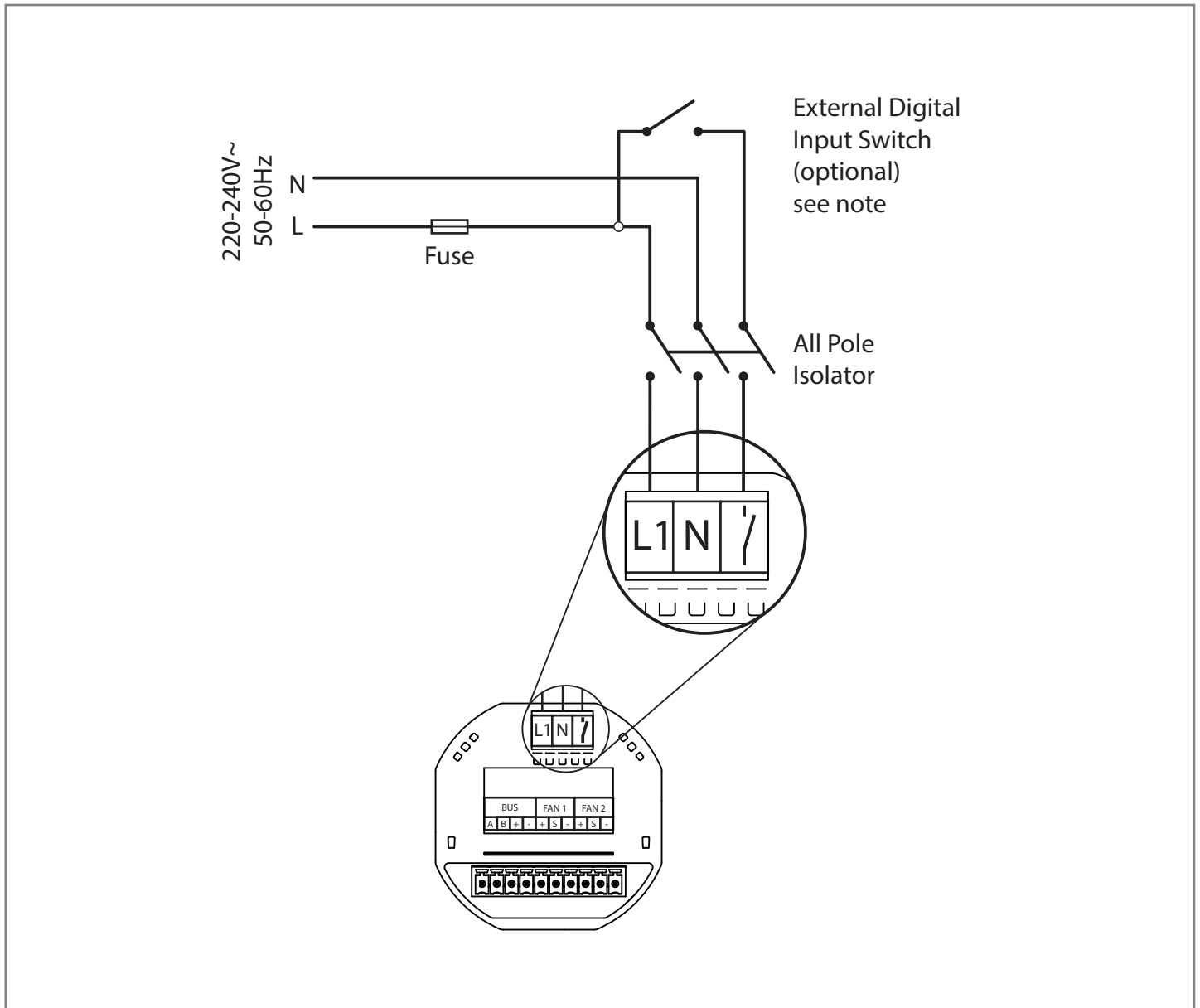

Mains Connection ref EE191

**Note:** It is mandatory that the External Digital Input Switch is supplied from the same phase as the SRC1 to avoid the risk of high voltage, which could cause damage to the controller.

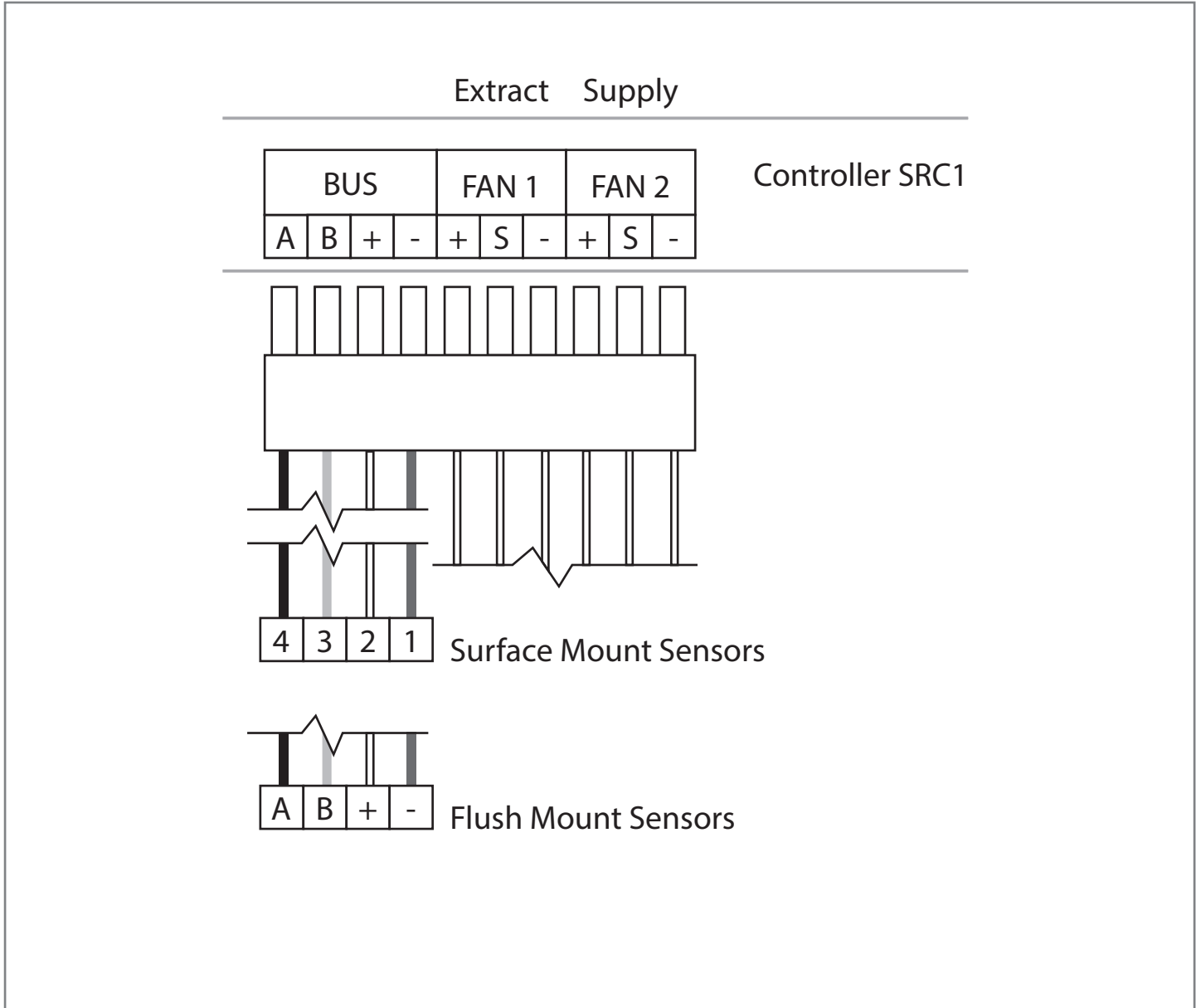

Sensor to controller connection

### Sensor Options

Sensor type	Surface mount	Flush mount
Relative humidity (RH) sensor	TP610	TP614
Carbon dioxide (CO <sub>2</sub> ) sensor	TP611	TP615
Combined relative humidity (RH) & Carbon dioxide (CO <sub>2</sub> ) sensor	TP612	TP616
Volatile organic compound (VOC)/ Air quality sensor	TP613	TP617

# Commissioning & Controls

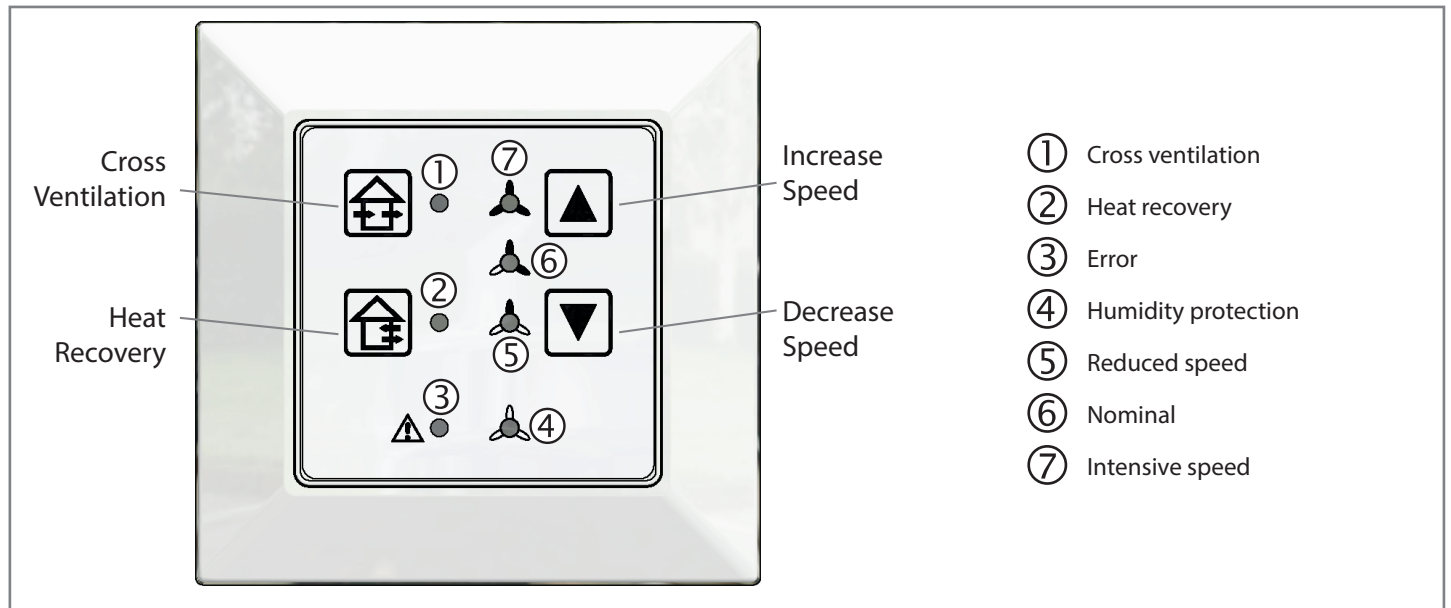

Controller

## Operation

The fans can operate either in heat recovery mode (default) or in cross ventilation mode. In heat recovery mode, the fans will change direction periodically. In cross ventilation mode, the fans will not change direction.

## Heat Recovery Mode

In Heat Recovery Mode the Supply and Extract fans change directions at regular intervals, warming the Heat Cell when extracting from the dwelling and recovering the stored heat when supplying air to the dwelling. This is the default operating mode.

## Cross Ventilation Mode

In warm weather when heat recovery is not required Cross Ventilation mode simply supplies air to one side of the dwelling and extracts from the other to create a cooling flow of air. By default Cross Ventilation is continuous, but it may have a timer configured by the installer (4, 8, 12 or 24 Hours). If a timer has been selected this will be indicated by LED 1 slowly flashing and once the timer has expired the controller will return to Heat Recovery mode. A second press of the Cross Ventilation button switches from timer to continuous.

## Fan Speeds

The device can run 4 different fan speeds as defined by DIN 1946-6

### Fan setting 1 (Large dwelling)

Sleep Mode**	6.5m <sup>3</sup> /h or Off
Off**	
Humidity Protection	6.5m <sup>3</sup> /h
Reduced	20m <sup>3</sup> /h
Nominal	40m <sup>3</sup> /h
Intensive	60m <sup>3</sup> /h

\*\*Configurable in the service menu

### Fan setting 2 (Small dwelling)

Sleep Mode**	6.5m <sup>3</sup> /h or Off
Off**	
Humidity Protection	6.5m <sup>3</sup> /h
Reduced	10m <sup>3</sup> /h
Nominal	17m <sup>3</sup> /h
Intensive	25m <sup>3</sup> /h

## Sensor Mode

When sensors are used, the number connected is entered via the Service Menu and the correct number selected on each sensor encoder (see image). See below table for encoder settings.

Quantity of Sensors	Encoder settings			
	Sensor 1	Sensor 2	Sensor 3	Sensor 4
1	0	X	X	X
2	0	1	X	X
3	0	1	2	X
4	0	1	2	3

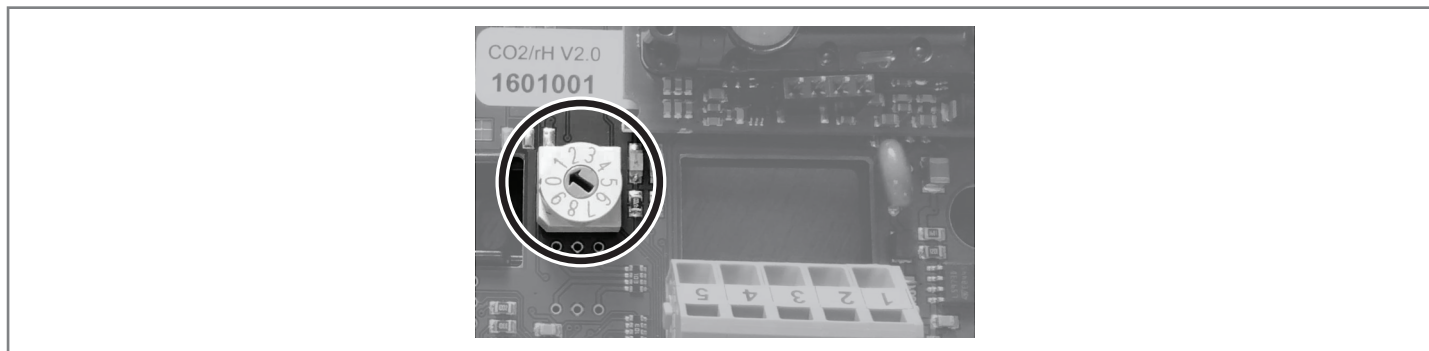

Sensor PCB, Encoder Highlighted

The type of sensor will be detected automatically. For every type of sensor there are 3 threshold levels. The parameters are Humidity, CO<sub>2</sub> and VOC threshold. For humidity only, one of three different sets of thresholds can be selected in the service menu. See below table of thresholds.

Function threshold	Fan speed	Threshold value
CO <sub>2</sub> threshold	2	800ppm
	3	1000ppm
	4	1200ppm
VOC threshold	2	800ppm
	3	1000ppm
	4	1200ppm
Humidity threshold low	2	35 %RH
Humidity threshold low	3	50 %RH
Humidity threshold low	4	65 %RH
Humidity threshold medium	2	40 %RH
Humidity threshold medium	3	55 %RH
Humidity threshold medium	4	70 %RH
Humidity threshold High	2	45 %RH
Humidity threshold High	3	60 %RH
Humidity threshold High	4	75 %RH

Whenever the lowest threshold is exceeded, the fan level will be set to the reduced fan level. The second threshold will trigger the nominal fan level, and the third sensor threshold will request the intensive fan level. The fan level will be active until the corresponding threshold is undercut. There is a hysteresis of 5%RH or 50ppm active when switching between the fan levels. Whenever the current fan level is manually altered, the sensor driven fan level will be deactivated for the duration of 1 hour.

## Sleep Mode

The SRC1 has a digital input which is used to activate Sleep Mode. The digital input requires a 220-240V~ supply via a switch, see Wiring, Mains.

**It is mandatory that the External Digital Input Switch is supplied from the same phase as the SRC1 to avoid the risk of high voltage, which could cause damage to the controller.**

Operating the switch puts the unit into Sleep Mode; By putting the unit to sleep, fans can be configured to either stop (default) or slow to humidity protection level for a period of time (default 1 hour) after which they will return to the previous setting. A second switch operation before the timer has expired brings the controller out of Sleep Mode. Sleep Mode can also be activated by pressing and holding the down arrow on the SRC1 keypad. The length of time the unit remains in Sleep Mode is configurable in the Service Menu. It is also possible to configure the fans to run at one of the other fan speeds during Sleep Mode.

## Filter Monitoring

The control unit has an integrated filter timer. The timer will operate whenever the fans are running. When the filter timer has expired the "ERROR" LED will illuminate continuously. The filter timer can be reset by holding both right hand side buttons for five seconds. The reset will be acknowledged by all LEDs flashing three times.

# Service Menu

The Service Menu can be used to configure external sensors and adjust other controller parameters and is based on the buttons and the LEDs. In order to enter the service menu, the two left buttons have to be held for at least five seconds. When in service mode, all three LEDs on the left side (cross ventilation, heat recovery and error) will be activated, either flashing or permanently lighting up. By these three LEDs, the current active service menu can be identified. When in service mode, the two left buttons can be used to move through the different settings of the service menu. The right hand side buttons will change the selected parameter value. The three LEDs on the right side will be used to show the value of the currently selected parameter. Each LED combination will represent a parameter value as shown in the table below.

Value	LED Number		
	5	6	7
1	1	0	0
2	0	1	0
3	1	1	0
4	0	0	1
5	1	0	1
6	0	1	1
7	1	1	1

Whenever a value has been edited, it has to be saved first, in order to take effect. To save the edited value, the button on the top left has to be held for three seconds. The saving will be acknowledged by a flashing of the right side LEDs.

In order to leave the service menu, the left bottom button must be held for three seconds. The Controller will switch back to the normal operation display. Whenever no button is pressed for a period of two minutes, the Controller will fall back to normal operation display.

The different parameters in service menu are shown in the table below.

Number	LED	Display	Menu
1	1 ON 2 ON 3 OFF		Number of sensors 1=no sensors (Default) 2=1 sensor 3=2 sensors 4=3 sensors 5=4 sensors
2	1 ON 2 ON 3 FLASH		Duration of sleep timer, mins 1=15 2=30 3=45 4=60 (Default) 5=120
3	1 ON 2 OFF 3 ON		Fan level in sleep mode 1=OFF (Default) 2=level 1 3=level 2 4=level 3 5=level 4
4	1 ON 2 FLASH 3 ON		Duration of times intensive ventilation, mins 1=15 2=30 3=45 4=60 (Default) 5=120
5	1 OFF 2 ON 3 ON		Duration of cross ventilation, hours 1=permanent (Default) 2=4 3=8 4=12 5=24

Number	LED	Display	Menu
6	1 2 3	FLASH ON ON	Function of digital input 1=sleep timer (Default)
7	1 2 3	FLASH ON OFF	Fan level off allowed 1=not allowed (Default) 2=allowed
8	1 2 3	FLASH ON FLASH	Sensor sensitivity 1=low 2=medium (Default) 3=high
9	1 2 3	FLASH OFF ON	LED brightness Increase and decrease using UP and DOWN arrows.
10	1 2 3	ON FLASH FLASH	Fan selection 1=Fan settings 1 (Default) 2=Fan settings 2
11	1 2 3	FLASH FLASH FLASH	Factory Defaults 6=restore factory defaults

## Errors

LED 3 is used to indicate errors which may occur with the controller. The number of times the LED flashes followed by a pause indicates the type of error, these are detailed below:

Number	Error	Error LED Indication	Recommended Action
1	Filter Timer expired	LED ON	Replace/Clean Filters & Reset Timer.
2	Self test failed	2 x FLASH - PAUSE	Contact the installer.
3	Sensor Communication error	3 x FLASH - PAUSE	Check wiring to the sensor(s), contact the installer.
4	Controller temperature too high	4 x FLASH - PAUSE	Contact the installer.



**MARKETING DIVISION**

894 The Crescent, Colchester Business Park, COLCHESTER, CO4 9YQ

Tel: +44 (0) 1206 713800 Fax: +44 (0) 1206 543126

Email: [ventsales@titon.co.uk](mailto:ventsales@titon.co.uk) Web: [www.titon.com](http://www.titon.com)