



# Ceiling Air Valve (Supply) Fire Rated



The fire rated air valve is manufactured from white epoxy coated powder coated steel. The valve has a male spigot to fit inside a ducting 100/125/150 system depending on selection.

The extract air valve is fully adjustable and has a locking nut to fix the position of the control disc upon commissioning. It is supplied complete with fixing body and pre-drilled holes for installation.

The Fire Rated air valve incorporates an integral intumescent material and has been fire tested to BS EN 1365-2:2014 with 60 minutes rating for ceilings.

The valve engages/disengages to the fixing body by a quarter turn clockwise/anticlockwise.

## Product Specification

Ceiling Metal Vent Diffuser - Supply			
Part Number	8960276	8960233	8960275
Size	100mm	125mm	150mm
Colour	RAL9016	RAL9016	RAL9016
Operating Temperature			
Max	+60°C	+100°C	+60°C
Min	-15°C	-20°C	-15°C
Weight	272g	334g	510g

## Drawing and Dimensions

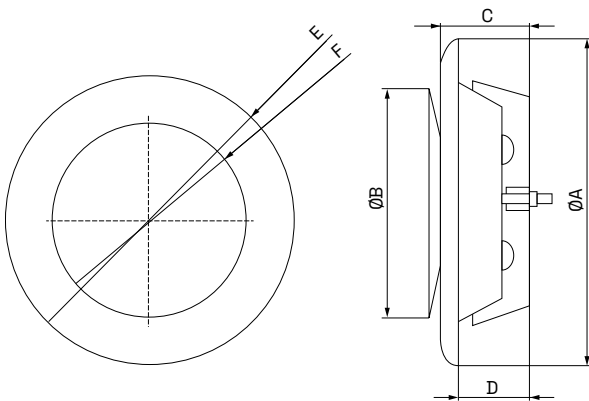

	100mm	125mm	150mm
ØA	138	162	201
ØB	94	114	135
C	40	44	51
D	32	36	38.5
ØE	138	163	202
ØF	94	114	135

Dimensions in mm

## Performance Details

Airflow l/s	100mm (Pa)	125mm (Pa)	150mm (Pa)
8	6	6	2
13	12	10	3
21	33	20	7
30	67	36	15
60	280	132	57
120	1150	430	227

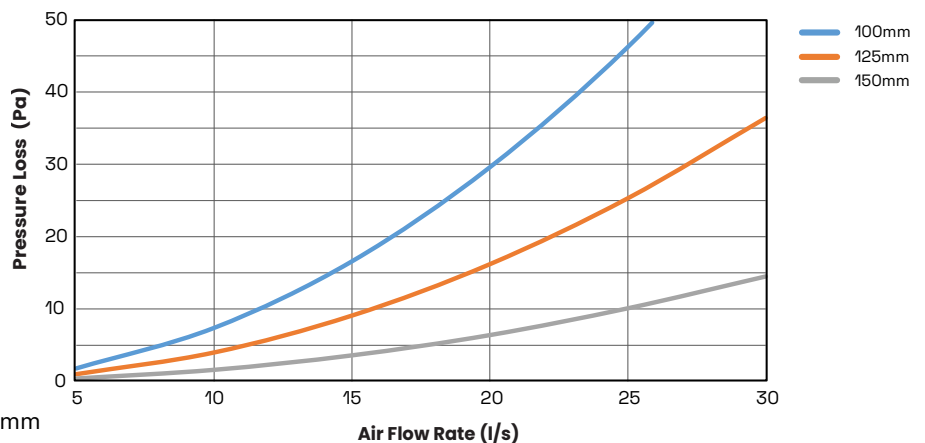

Pressure loss with control disc open to 10mm